

Table of Contents

1 Summary	3
1.1 Name plate	3
1.2 Product series	4
1.3 Technical standards	6
1.4 Peripheral Electrical Devices and System Configuration	8
1.5 Product outline and installation dimensions	9
2 Wirings	14
2.1 Standard wiring diagrams	14
2.2 Main circuit wiring terminals	16
2.3 Control circuit wiring terminals	17
3 Panel operations	23
3.1 Keyboard interface	23
3.2 Parameter setting example & motor auto-tuning	25
3.3 JOG	26
4 Function codes (Parameters)	27
4.1 Basic monitoring parameters: d0.00-d0.41	27
4.2 Basic functions group: P0.00-P0.28	31
4.3 First motor parameters: P1.00-P1.37	41
4.4 V/F control parameters: P2.00-P2.15	46
4.5 Vector control parameters: P3.00-P3.22	51
4.6 Input terminals: P4.00-P4.39	55
4.7 Output terminals: P5.00-P5.22	68
4.8 Start/stop control: P6.00-P6.15	74
4.9 Operation panel and display: P7.00-P7.14	79
4.10 Auxiliary functions: P8.00-P8.53	82
4.11 Fault and protection: P9.00-P9.70	92
4.12 PID functions: PA.00-PA.28	103
4.13 Swing Frequency, Fixed Length and Count: PB.00-PB.09	108
4.14 Multi-reference and simple PLC: PC.00-PC.51	111
4.15 Communication parameters: PD.00-PD.06	116
4.16 PE group: reserved	117
4.17 Function code management: PP.00-PP.04	117
4.18 Torque control parameters: B0.00-B0.08	119
4.19 Control optimization parameters: B5.00-B5.09	121
4.20 Extended function parameters: B9.00-B9.09	123

5 Fault and solutions	124
5.1 Fault and solutions.....	124
5.2 Common fault and solutions.....	130
6 Repair and maintenance	132
6.1 Routine maintenance.....	132
6.2 Replacement of vulnerable components.....	132
7 MODBUS communication protocol	133
7.1 Communication protocol.....	133
7.2 Verification mode.....	136
7.3 Communication addresses.....	137
Appendix I: Parameter list	141
Appendix II: Expansion cards	156
Appendix II-1 Multi-function card DLB1-PC1	156
Appendix II-2 Encoder card (PG card)	158
Appendix III Brake accessories	162
Appendix IV: Selection of Peripheral Electrical Devices	164
Appendix V: Guide for complying with EMC	169
Appendix VI: Safety instructions	171

1 Summary

1.1 Name plate

Model	→	MODEL: DLB1-0011T4G
Power	→	POWER: 11kW
Input power	→	INPUT: AC3PH 380V 50Hz/60Hz 27.6A
Output	→	OUTPUT: AC3PH 0~380V 0~300Hz 25A
Barcode	→	S/N:

Graph 1-1 Nameplate

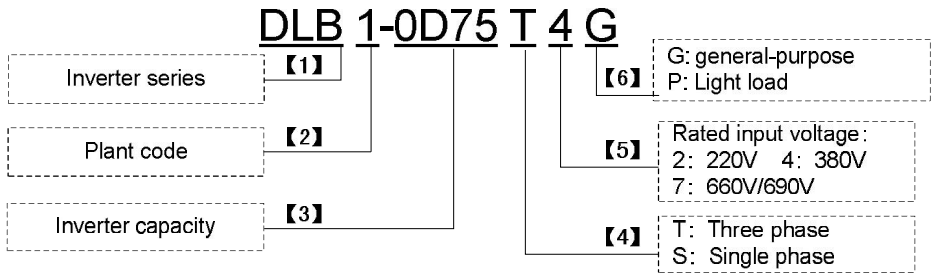

④

【1】 Inverter series

Mark	Specification
DLM	M series
DLB	B series

【2】 Plant code

Mark	Specification
1	General purpose

【3】 Inverter capacity

Mark	Specification
0D40	400W
0D75	750W
01D5	1.5KW
02D2	2.2KW

【4】 Power phase

Mark	Specification
S	Single phase
T	Three phase

【5】 Input voltage

Mark	Specification
2	220V
4	380V

【6】 Inverter type

Mark	Specification
G	General-purpose
P	Light load

Important:

Please read Appendix VI Safety Instructions carefully before and during using JADEN DLB1 inverters.

1.2 Product series

Inverter model	Rated output power (kW)	Rated input current (A)	Rated output current (A)
Single Phase input:AC 220V-15%~+10%, 50/60Hz			
DLB1-0D40S2G	0.4	5.9	2.5
DLB1-0D75S2G	0.75	8.3	4
DLB1-01D5S2G	1.5	14.1	7
DLB1-02D2S2G	2.2	24.2	10
Three phase input:AC 380V-15%~+10%, 50/60Hz			
DLB1-0D75T4G	0.75	4.3	2.5
DLB1-01D5T4G	1.5	5.2	3.7
DLB1-02D2T4G	2.2	6.0	5
DLB1-0004T4G	4.0	10.5	8.5
DLB1-05D5T4G	5.5	15.5	13
DLB1-07D5T4G	7.5	20.5	16
DLB1-0011T4G	11	27.6	25
DLB1-0015T4G	15	37.1	32
DLB1-0018T4G	18	41.9	38
DLB1-0022T4G	22	49.3	45
DLB1-0030T4G	30	65.7	60
DLB1-0037T4G	37	80.6	75
DLB1-0045T4G	45	96.4	90
DLB1-0055T4G	55	117.6	110
DLB1-0075T4G	75	166.4	150
DLB1-0090T4G	90	184.3	170
DLB1-0110T4G	110	226.8	210
DLB1-0132T4G	132	268.1	250
DLB1-0160T4G	160	321.1	300
DLB1-0187T4G	187	368.0	340
DLB1-0200T4G	200	406.6	380
DLB1-0220T4G	220	442.7	415
DLB1-0250T4G	250	503.0	470
DLB1-0280T4G	280	555.9	520
DLB1-0315T4G	315	650.7	600

DLB1-0355T4G	355	754.5	650
DLB1-0400T4G	400	797.6	725
Three phase input: AC 660V-15%~-+10%, 50/60Hz			
DLB1-0D75T7G	0.75	4.1	2.5
DLB1-01D5T7G	1.5	4.9	3.7
DLB1-02D2T7G	2.2	5.7	5
DLB1-0004T7G	4.0	9.4	8
DLB1-05D5T7G	5.5	12.5	11
DLB1-07D5T7G	7.5	18.3	15
DLB1-0011T7G	11	23.1	22
DLB1-0015T7G	15	29.8	27
DLB1-0018T7G	18	35.7	34
DLB1-0022T7G	22	41.7	40
DLB1-0030T7G	30	57.4	55
DLB1-0037T7G	37	66.5	65
DLB1-0045T7G	45	81.7	80
DLB1-0055T7G	55	101.9	100
DLB1-0075T7G	75	137.4	130
DLB1-0090T7G	93	151.8	147
DLB1-0110T7G	110	185.3	180
DLB1-0132T7G	132	220.7	216
DLB1-0160T7G	160	264.2	259
DLB1-0187T7G	187	309.4	300
DLB1-0200T7G	200	334.4	328
DLB1-0220T7G	220	363.9	358
DLB1-0250T7G	250	407.9	400
DLB1-0280T7G	280	457.4	449
DLB1-0315T7G	315	533.2	516
DLB1-0355T7G	355	623.3	570
DLB1-0400T7G	400	706.9	650

1.3 Technical standards

		Specifications		
Basic functions	Control system	Current/Vector General Purpose Inverter.		
	Compatible motor	Induction motor and Synchronous motor.		
	Maximum frequency	Vector control:0~300Hz; V/F control:0~3200Hz.		
	Wave-carrier frequency	0.5kHz~16kHz; Depending on load, can automatically adjust wave-carrier frequency.		
	Input frequency resolution	Digital setting:0.01Hz; Analog setting:maximum frequency×0.025%.		
	control mode	Open vector control(SVC); Closed loop vector control(FVC); V/F control.		
	Starting torque	G type:0.5Hz/150%(SVC); 0Hz/180%(FVC). P type:0.5Hz/100%.		
	Speed range	1:100(SVC)	1:1000(FVC)	
	Speed stability accuracy	±0.5%(SVC)	±0.02%(FVC)	
	Torque control accuracy	±5%(FVC)		
	Overload capacity	G type:150%rated current60s; 180%rated current3s; P type:120%rated current60s; 150%rated current3s.		
	Torque boost	Automatic or manual 0.1%~30.0%.		
	V/F curve	<ul style="list-style-type: none"> • Straight-line V/F curve • Multi-point V/F curve • N-power V/F curve (1.2-power, 1.4-power, 1.6-power, 1.8-power, 2-power square) 		
	V/F separation	Two types: complete separation; half separation. AVR output.		
	Ramp mode	<ul style="list-style-type: none"> • Straight-line ramp • S-curve ramp Four groups of acceleration/deceleration time with the range of 0.0~6500.0s		
	DC braking	DC braking frequency: 0.00 Hz to maximum frequency Braking time: 0.0~36.0s Braking action current value: 0.0%~100.0%		
	JOG control	JOG frequency range: 0.00~50.00 Hz JOG acceleration/deceleration time: 0.0~6500.0s		
	Simple PLC	Up to 16 speeds via the simple PLC function or combination of DI terminal states		
	Onboard PID	Process-controlled closed loop control system		
	Auto voltage regulation (AVR)	Keep constant output voltage automatically when grid voltage fluctuates.		
Overvoltage/ Overcurrent stall control	The current and voltage are limited automatically during the running process so as to avoid frequent tripping due to overvoltage/overcurrent.			
Fast current limit function	Protect inverter from overcurrent malfunctions.			
Torque limit and control	It can limit the torque automatically and prevent frequent over current tripping during the running process. Torque control can be implemented in the FVC mode.			

Special Functions	Power dip ride through	The load feedback energy compensates the voltage reduction so that the Inverter can continue to run for a short time.
	Timing control	Time range: 0.0–6500.0 minutes
	Two-motor switchover	Two motors can be switched over via two groups of motor parameters.
	Fieldbus	Supports RS485, Profibus-DP, CANlink, CANopen (need extension cards)
	Background software	Change inverter parameter & virtual oscillograph to monitor inverter status.
Operations	Command source	<ul style="list-style-type: none"> • Operation panel • Control terminals • Serial communication port You can perform switchover between these sources in various ways.
	Frequency source	11 frequency sources, such as digital setting, analog voltage setting, analog current setting, pulse setting and serial communication port setting. You can perform switchover between these sources in various ways.
	Auxiliary frequency source	11 auxiliary frequency sources. It can implement fine tuning of auxiliary frequency and frequency synthesis.
	Input terminal	6 digital input (DI) terminals, DI5 supports up to 100 kHz high-speed pulse input; 3 analog input (AI) terminals, support 0–10 V voltage input or 4–20 mA current input
	Output terminal	2 digital output (DO) terminal (FM supports 0–10 kHz square wave signal output) 1 relay output terminal 2 analog output (AO) terminal that support 0–20 mA current output or 0–10 V voltage.
Display and panel	LED display	Displays parameters.
	Key lock	It can lock the keys partially or completely and define the function range of some keys so as to prevent mis-function.
	Protection function	Motor short-circuit detection at power-on, input/output phase loss protection, overcurrent protection, overvoltage protection, undervoltage protection, overheat protection and overload protection
	Optional parts	PG card, brake unit, RS485 card, CAN card, Profibus-DP card
Environment	Location	Indoor, free from direct sunlight, dust, corrosive gas, combustible gas, oil smoke, vapour, drip or salt.
	Altitude	Lower than 1000m.
	Ambient temperature	-10°C to +40°C (de-rated if the ambient temperature is between 40°C and 50°C)
	Humidity	Less than 95%RH, without condensing
	Vibration	Less than 5.9m/s ² (0.6g).
Storage temperature	- 20 ~ + 60 .	

1.4 Peripheral Electrical Devices and System Configuration

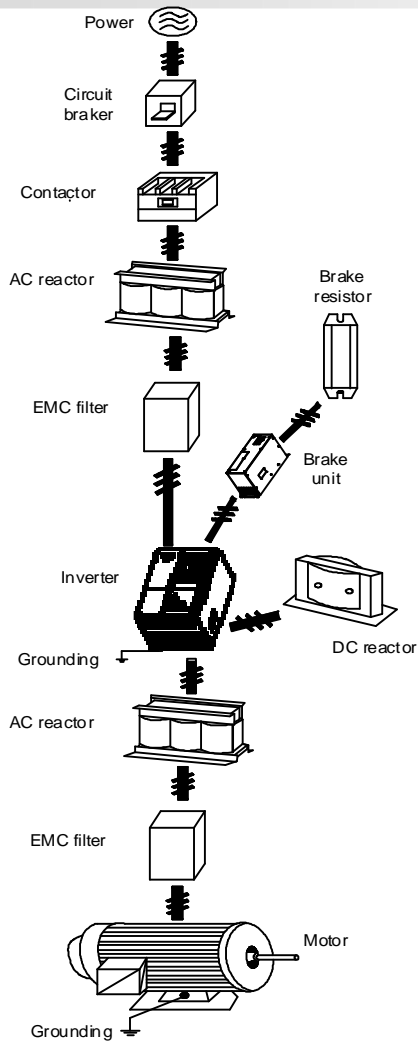

Graph 1-2 Peripheral electrical devices

1.5 Product outline and installation dimensions

1.5.1 Product outline& installation dimensions

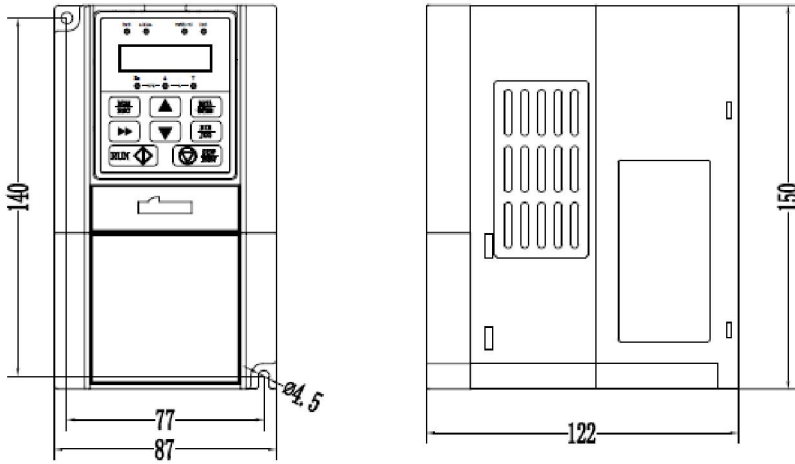

Graph 1-3 0.4W~1.5KW product outlines & dimensions

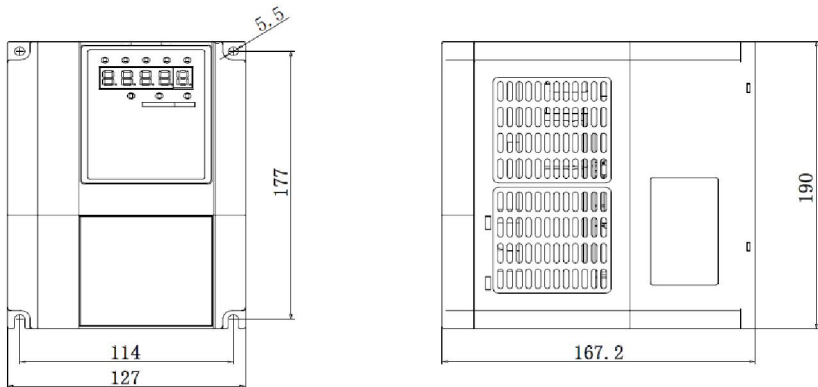

Graph 1-4 2.2KW ~ 3.7KW product outline & dimensions

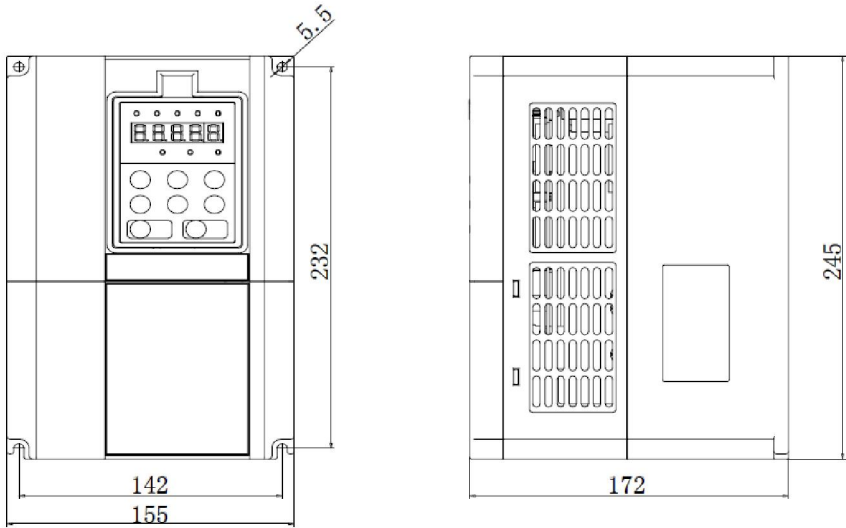

Graph 1-5 5.5 ~ 7.5KW product outline & dimensions

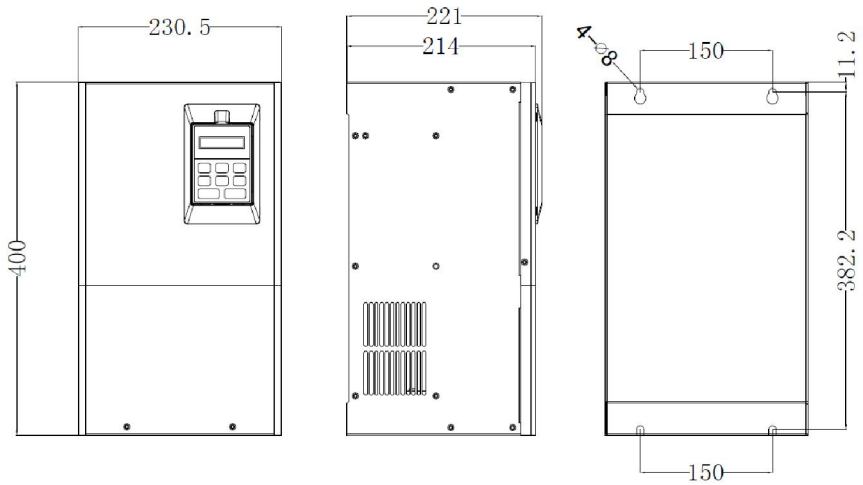

Graph 1-611-18.5KW product outline & dimensions

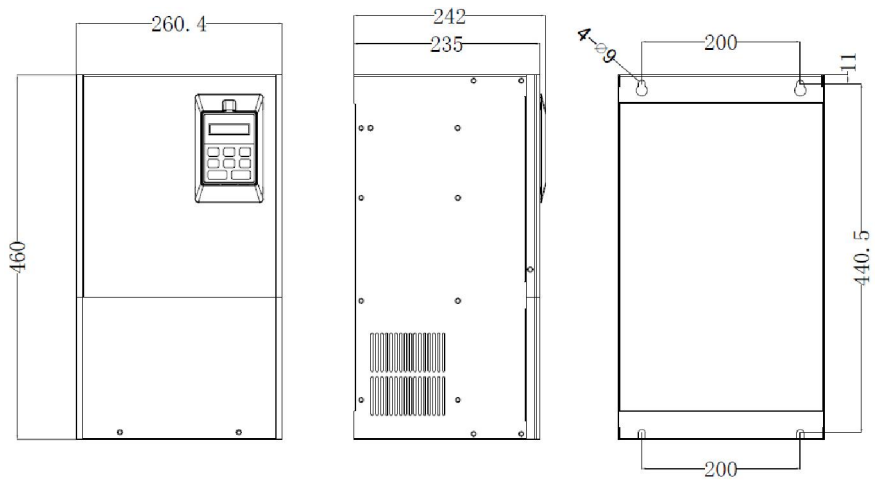

Graph 1-722~30KW product outline & dimensions

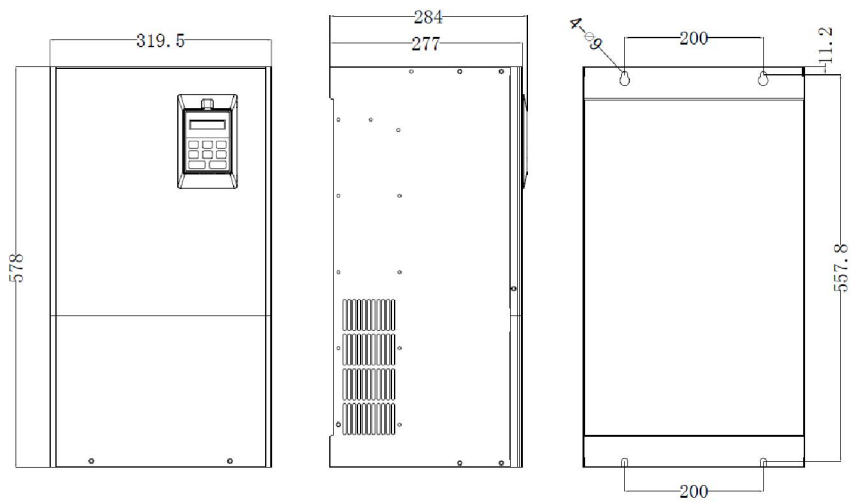

Graph 1-837~55KW product outline & dimensions

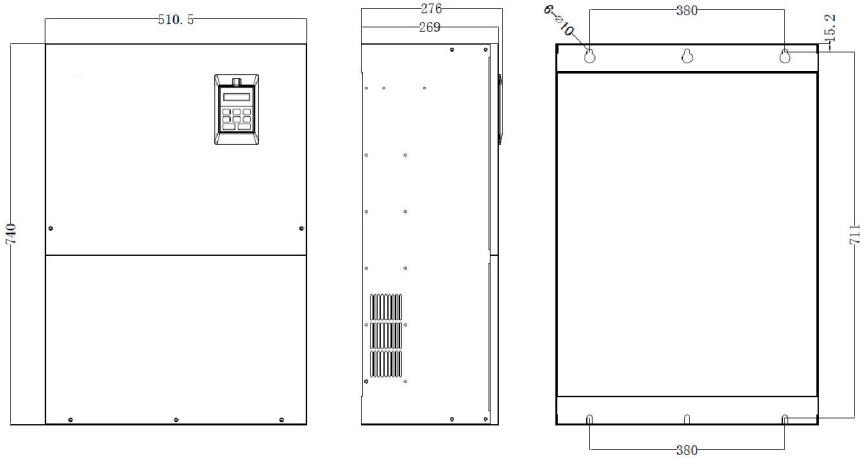

Graph 1-875~110KW product outline & dimensions

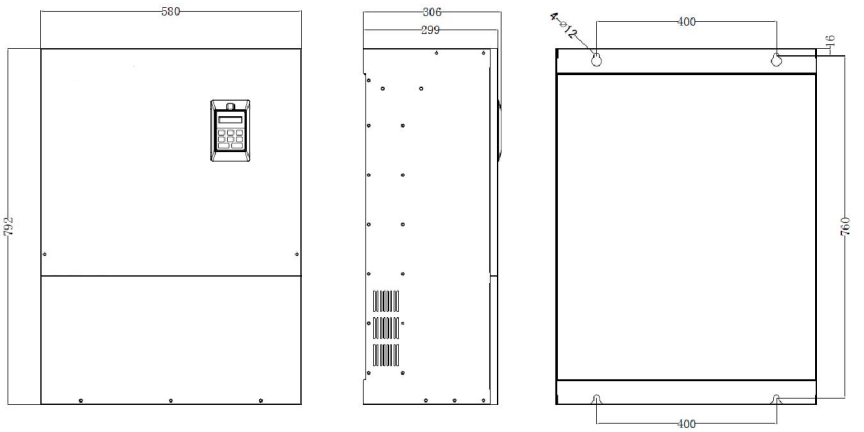

Graph 1-9 132 ~ 160KW product outline & dimensions

1.5.2 Detachable keyboard(operation panel) dimensions

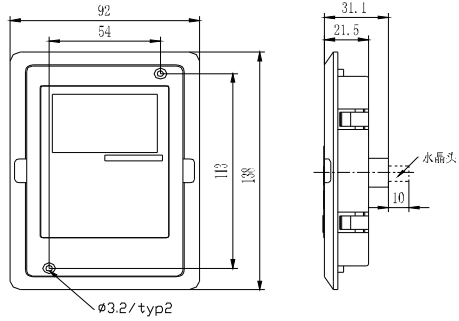

Graph 1-10 detachable keyboard outline dimensions

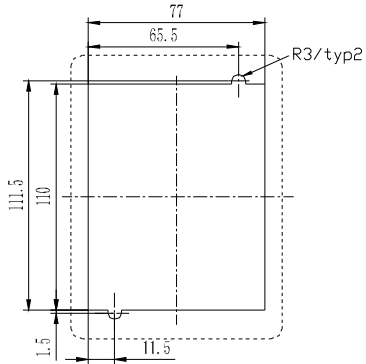

Graph 1-11 detachable keyboard aperture dimensions

2 Wirings

2.1 Standard wiring diagrams

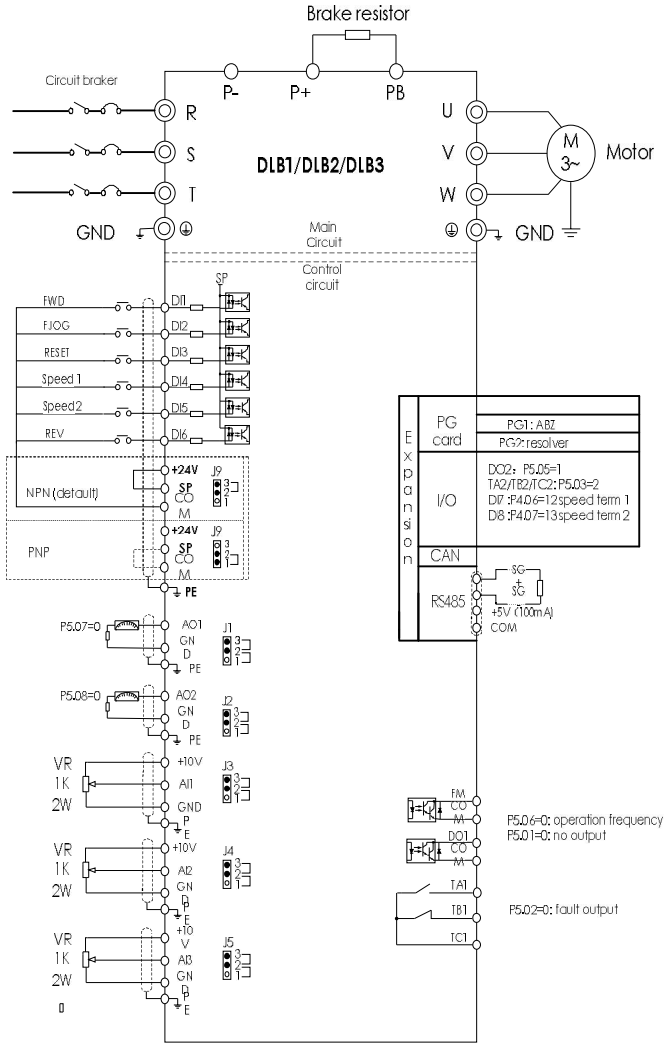

Graph 2-8 0.4~18.5KW inverter wiring diagram

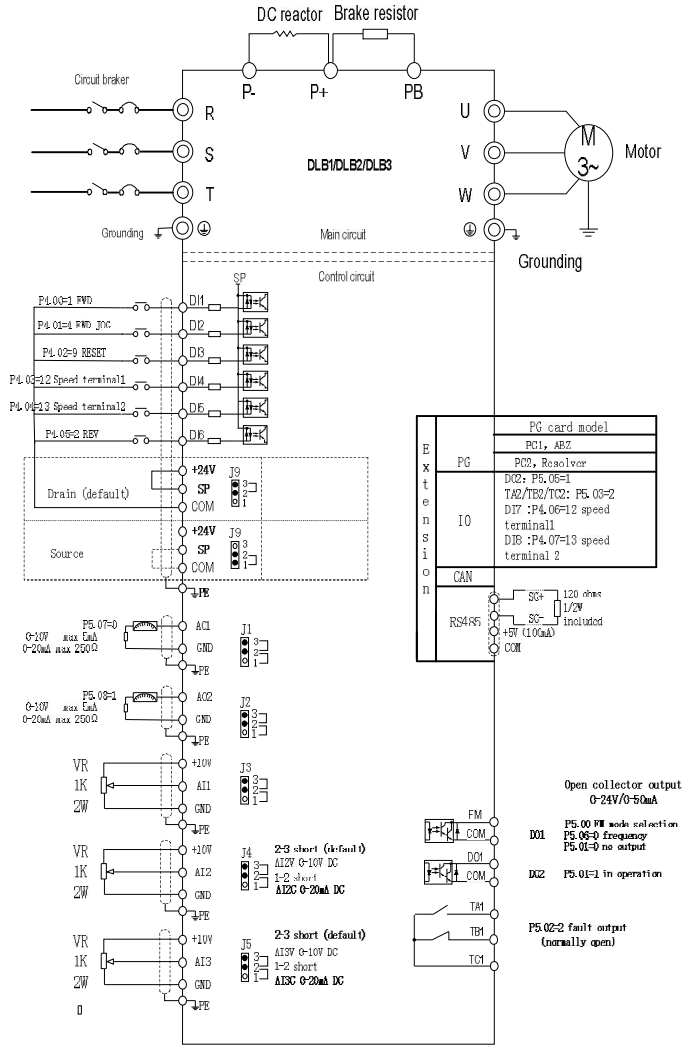

Graph 2-922 ~ 400KW inverter wiring diagram

2.2 Main circuit wiring terminals

0.4KW~15KW:

P+	P-	PB	R	S	T	PE	U	V	W
----	----	----	---	---	---	----	---	---	---

Terminal name	Function
R, S, T	Three phase power input terminal
P+, PB	External brake resistor terminal
P-	DC bus negative terminal
U, V, W	Three phase AC output terminal
PE	Grounding terminal

18.5KW~400KW:

	R	S	T	(+) P (-)	U	V	W
	POWER				MOTOR		

Terminal name	Function
R, S, T	Three phase power input terminal
(+), (-)	External brake unit terminal
P, (+)	External DC reactor terminal
U, V, W	Three phase AC output terminal
	Grounding terminal

2.3 Control circuit wiring terminals

2.3.1 Control circuit terminal definitions

GND	AO1	AO2	A1	A2	A3	DI2	DI4	DI6	DO1	COM	TC1
GND	+10V	+24V	SP	COM	DI1	DI3	DI5	FM	+24V	TA1	TB1

2.3.2 Control circuit signals

Category	Terminal	Name	Function	Specifications
Input	Digital	DI1	Multi-function input terminal X1 Default setting: Forward operation(FWD)	Optical coupler insulation DC24V/8mA When using external power supply, voltage range: 9 ~ 30V DI5 can configure as high speed pulse input. pulse range: 0 ~ 100kHz.
		DI2	Multi-function input terminal X2 Default setting: Forward JOG(FJOG)	
		DI3	Multi-function input terminal X3 Default setting: Fault reset (RESET)	
		DI4	Multi-function input terminal X4 Default setting: Multi-speed terminal1	
		DI5	Multi-function input terminal X5 Default setting: Multi-speed terminal12	
		DI6	Multi-function input terminal X6 Default setting: REV operation(REV)	
		SP	Multi-function input common Default: +24V short-circuit with SP by jumper	
	Analog	10V	Analog 10V Power Output capacity: 10mA or below, 1k ~5k	0 ~ 20mA input: input impedance is 500 ohms.
		AI1	Analog frequency setting 1 DC: 0 ~ 10V or 0 ~ 20mA (resolution1/1000)	0 ~ 10V input: input impedance is 20K ohms.
		AI2	Analog frequency setting 2 DC: 0 ~ 10V or 0 ~ 20mA (resolution1/1000)	
AGND		Analog common 0V		

Category	Terminal	Name	Function	Specifications	
		terminal			
Output	Relay	TA1	A node output	Default setting: stop fault during operation TA1—TC1: normally open TB1—TC1: normally close	Node capacity: AC250V, 3A.
		TB1	B node output		
		TZ1	Node output common terminal		
	Digital	DO1	Open collector output 1	Default setting: inverter in operation	open collector output; Optical-coupler output capacity: Below DC24V, 50mA.
		FM	High speed pulse output	Pulse range: 0 ~ 100kHz. Open collector output.	Defined by P5.00: FM terminal output mode selection.
		COM	FM output common terminal		When used as high speed pulse output, maximum frequency is 100kHz.
	Analog	AO1	Analog monitor output1	Voltage or current output; Default setting: output frequency	Output voltage range: 0 ~ 10V; Output current range: 0 ~ 20mA.
		AO2	Analog monitor output2	Voltage or current output; Default setting: output frequency	
		AGND	Analog common terminal	0V	
	Power	+24V	DC24V power positive node	Used with DI, DO	Output capacity: below 200mA; Default: +24V short-circuit with SP
COM		DC24V power negative node			

2.3.3 Control circuit wiring notes

1. Analog input terminal

As analog voltage signals can be easily affected by external interference, shielded cables shall be used. Cables shall be as short as possible and not exceeding 20 meters. As shown in Graph 2-12 & 2-13, in some severe circumstances, filter capacitor or ferrite bead shall be used in analog signal side.

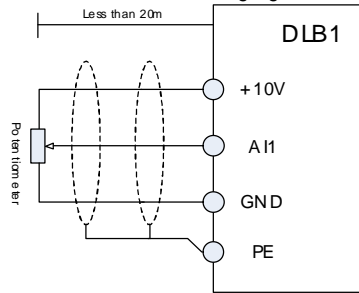

Graph 2-12 Analog input terminal wiring

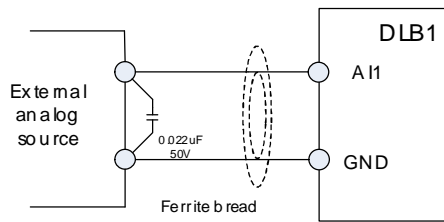

Graph 2-13 Analog input terminal treatment

2. Digital input terminal

Shielded cables shall be used. Cables shall be as short as possible and not exceeding 20 meters. When using active drive mode, user shall take necessary filter measures to counter power interference. It is recommended to use node control mode.

Digital inputs include NPN input and PNP input.

(a) NPN input: Most common. Use internal 24V power; +24V terminal short-circuit with SP terminal; COM terminal is common; J9 is 23 jumper; also known as drain wiring mode.

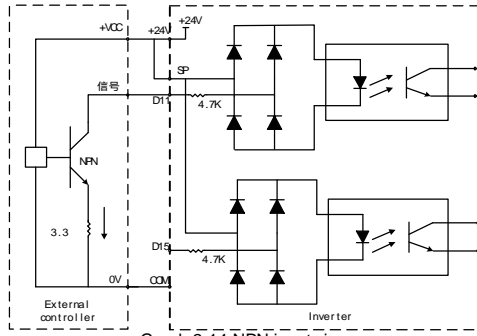

Graph 2-14 NPN input wiring

(b) PNP input: Use external 24V power; external power negative node is connected with SP terminal; external terminal positive node is common; external power voltage range is 9~30V; J9 is 12 jumper; also known as source wiring mode.

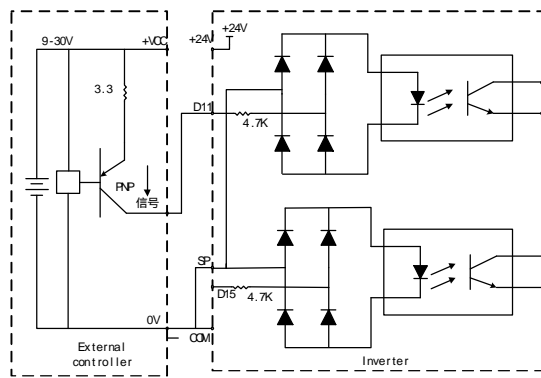

Graph 2-15 PNP input wiring

3. Output terminal

Digital output is open collector output. When using external power, please connect external power negative node to COM terminal. Maximum current is 50mA for open collector output. If external load is relay, please install fly-wheel diode to both ends of the relay.

◀ Note: please install fly-wheel diode polars correctly, otherwise internal components will be damaged.

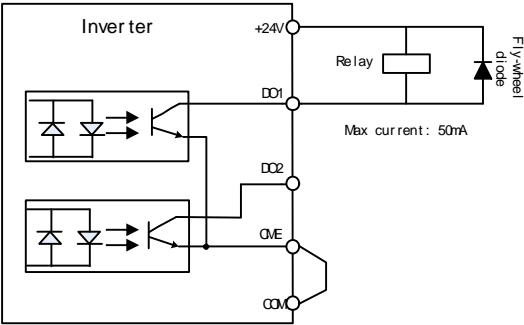

Graph2-16 Digital output wiring

2.3.4 Control circuit jumper

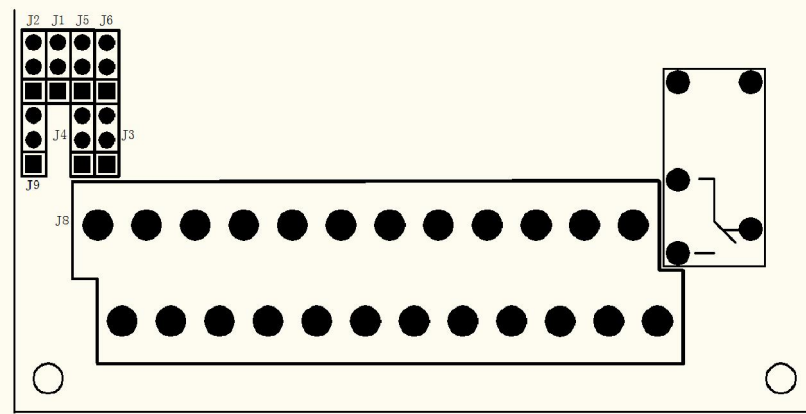

Graph 2-170.4KW~93KW control board jumpers

Control circuit jumper

1, SP jumper (J9)

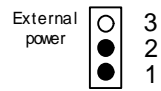
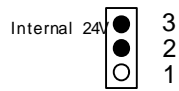

2, AO1 jumper (J1)

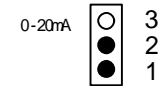
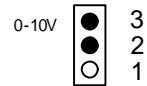

3, AO2 jumper (J2)

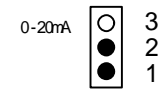
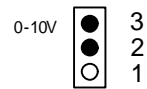

4, AI1 Jumper (J4)

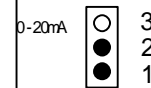
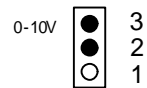

5, AI2 Jumper (J5)

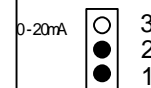
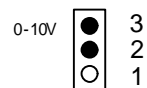

6, AI3 Jumper (J6)

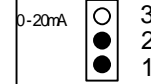
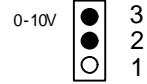

3 Panel operations

3.1 Keyboardinterface

Keyboard can edit inverter function parameters; monitor inverter work status; and control inverter operations such as start/stop. The outline is as below:

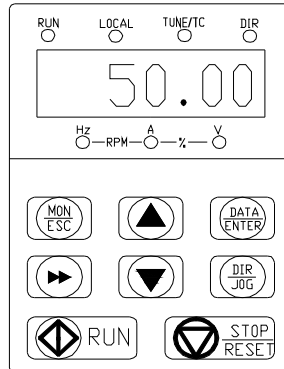

Panel functions

Keyboard/ Light	Descriptions
DIR	Direction ON:FWD status OFF:REV status
RUN	Operation ON:RUN status OFF: STOP status
LOCAL	Command source ON: terminal operation control status OFF: keyboard operation control status BLINK:remote operation control status
TUNE/TC	Tune/fault ON:torque control mode SLOW BLINK:tuning status FAST BLINK:fault status
Hz A V RPM(Hz+A) %(A+V)	Unit * Hz frequency unit *A current unit *V voltage unit *RPM(Hz+A) speed unit *%(A+V) percentage

Digital display	Can display setting frequency, output frequency, monitor data and fault etc.
MON/ESC	Program key: Enter level 1 menu or escape
>>	Shit key: Select parameter when at run or stop; When editing parameters, can select place for editing.
DATA/ENTER	Confirm key: Confirm parameters
	Increase key
	Decrease key
DIR/JOG	Multi-function selection key: Function switching set by P7.01.
RUN	Operation key: When under keyboard operation mode, used to start operation.
STOP/RESET	STOP/RESET key Set by P7.02

3.2 Parameter setting example& motor auto-tuning

Functioncode inspect and edit

DLB1 inverter panel has a three-level structure: function code group (level 1 menu)
function code (level 2 menu) function code setting (level 3 menu).

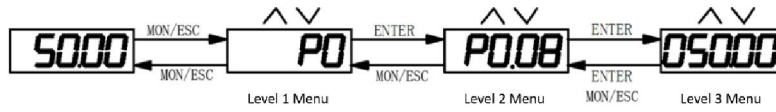

Graph 3-2

Example: Change P3.02 from 10.00Hz to 15.00Hz, as shown in Graph3-3.

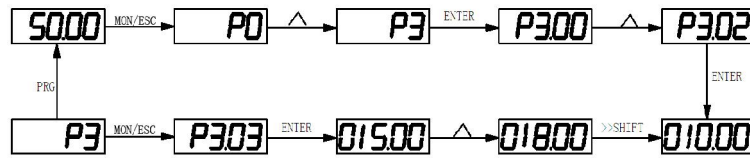

Graph 3-3

Parameter inspection

Please refer to P7.03, P7.04, P7.05 for parameter inspect settings.

Password setting

When PP.00 is not 0, inverter is under password protection. The password is as shown in PP.00.

To cancel password protection, user must enter the correct password and set PP.00=0.

Motor parameter auto-tuning

Procedures:

- 1) Set P0.02=0 (operation panel as command source channel)
- 2) Input motor actual parameters:

Motor selection	Parameters
Motor1	P1.00:motor type selection P1.01:rated power P1.02:rated voltageP1.03:rated current P1.04:rated frequencyP1.05:rated speed

- 3) If (asynchronous) motor can separate from load, set P1.37=2 (asynchronous motor complete auto-tuning) and press RUN key. The inverter will automatically calculate parameters below:

Motor selection	Parameters
Motor1	P1.06:asynchronous motor stator resistor P1.07:asynchronous motor rotorresistor P1.08:asynchronous motor leakage inductanceP1.09:asynchronous motor mutual inductance P1.10:asynchronous motor no load current

- 4) If (asynchronous) motor cannot separate from load, set P1.37=1 and press RUN key. Finish auto-tuning.

3.3 JOG

DLB1 series default setting value

Code	Default setting value	
P0.01	0	Sensorless vector control (SVC)
P0.02	0	Operation panel command channel (LED OFF)
P0.03	0	Keyboard setting frequency(P0.08, UP/DOWN can edit, not retentive at power failure)

After correctly set motor parameter P1.00-P1.05 and auto-tuning, user can control motor operation using keyboard.

4 Function codes (Parameters)

Legends:

- “ ” :this parameter's setting value is not editable when inverter is at operation status;
- “ ” :this parameter's value is observed value, not editable;
- “ ” :this parameter's setting value is editable when inverter is at stop or operation status;
- “ ” :this parameter is "factory parameter" not for editing;
- “ - ”:this parameter is depending on model.

4.1 Basic monitoring parameters:d0.00-d0.41

d0 parameter group is used for monitoring inverter operation status. User can read by panel display or by communications for remote controls. d0.00~d0.31 are defined by P7.03&P7.04 for operation & stop monitor parameters.

Function code	Name	Unit
d0.00	Running frequency(Hz)	0.01Hz
Inverter absolute value of theoretical running frequency.		
d0.01	Set frequency(Hz)	0.01Hz
Inverter absolute value of theoretical set frequency.		
d0.02	DC Bus voltage(V)	0.1V
DC bus voltage; detected value.		
d0.03	Output voltage(V)	1V
Inverter running state output voltage.		
d0.04	Output current(A)	0.01A
Motor running state output current.		
d0.05	Output power(kW)	0.1kW
Motor running state output power.		
d0.06	Output torque(%)	0.1%
Motor running state output torque percentage.		
d0.07	DI input status	1

This displays the current state of DI terminals. After the value is converted into a binary number, each bit corresponds to a DI. "1" indicates high level signal, and "0" indicates low level signal. The corresponding relationship between bits and DIs is described in the following table.

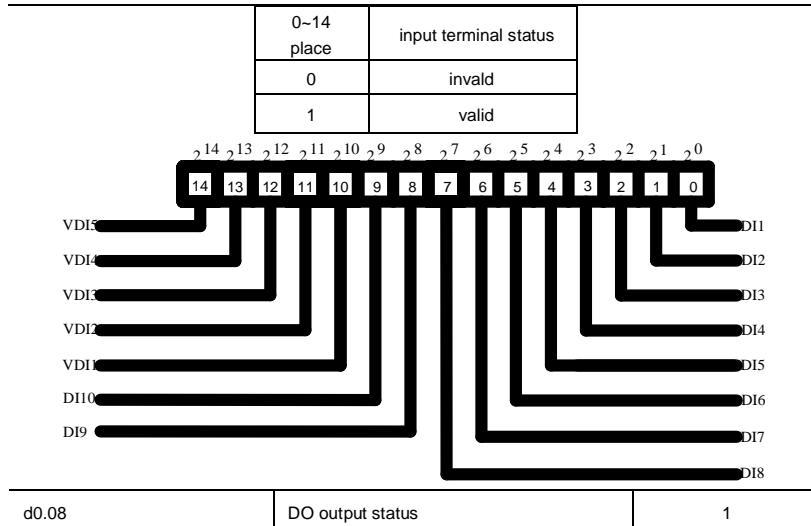

It indicates the current state of DO terminals. After the value is converted into a binary number, each bit corresponds to a DO. "1" indicates high level signal, and "0" indicates low level signal. The corresponding relationship between bits and DOs is described in the following table.

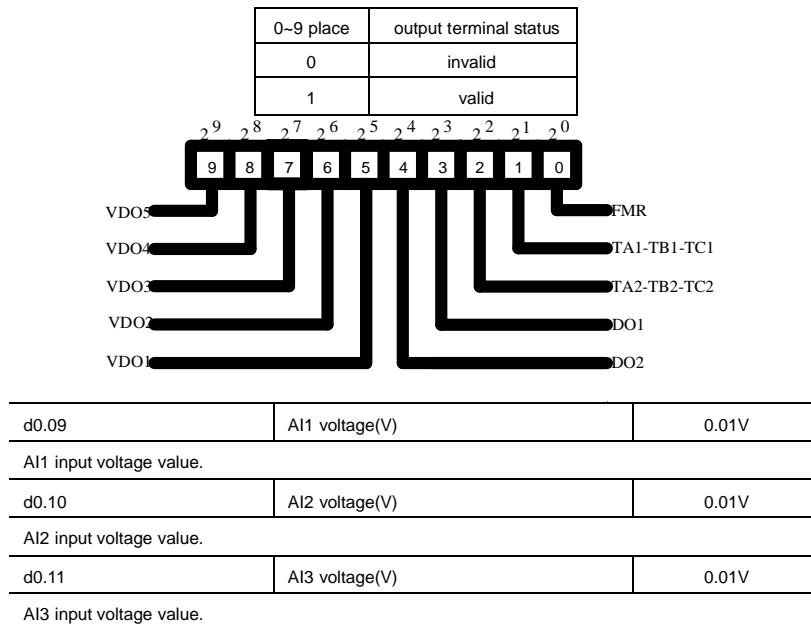

d0.12	Counter value	1
PB parameter group counter functionPB.08~PB.09.		
d0.13	Length value	1
PB parameter group fixed-length functionPB.05~PB.07.		
d0.14	Load speed display	1
Motor actual running speed.		
d0.15	PID setting	1
PIDpreset value percentage.		
d0.16	PID feedback	1
PID feedback value percentage.		
d0.17	PLC phase	1
PLC phase display.		
d0.18	HDI(DI5) pulse frequency(kHz)	0.01kHz
HDI(DI5) input pulse frequency display..		
d0.19	Feedback speed(unit0.1Hz)	0.1Hz
PG feedback speed, accurate to 0.1Hz.		
d0.20	Remaining running time	0.1Min
Used for timer control.		
d0.21	AI1 voltage before correction	0.001V
AI1voltage before correction.		
d0.22	AI2 voltage before correction.	0.001V
AI3 voltage before correction.		
d0.23	AI3 voltage before correction.	0.001V
AI3 voltage before correction.		
d0.24	Linear speed	1m/Min
Calculated from angular speed&diameter, used for constant tension& constant linear speed controls.		
d0.25	Present power-on time	1Min
This time inverter cumulative power-on time.		
d0.26	Present running time	0.1Min
This time inverter cumulative power-on time.		
d0.27	HDI(DI5) pulse frequency	1Hz
Input pulse frequency display.		
d0.28	Communication setting value	0.01%
It displays the data written by means of the communication address 0x1000.		

d0.29	Encoder feedback speed	0.01Hz
PG feedback speed, accurate to 0.1Hz.		
d0.30	Main frequencyX display	0.01Hz
P0.03 main frequency source setting value		
d0.31	Auxiliary frequencyY display	0.01Hz
P0.04 auxiliary frequency sourcesetting value.		
d0.32	Inverter status	1
d0.33	Target torque(%)	0.1%
Under torque control mode, monitortarget torque.		
d0.34	Motor temperature value	1
Motor temperature value display.Can also select different temperature measuring point to monitor temperature of other devices.		
d0.35	Synchronousmotor rotor position	0.0°
Synchronous motor rotor position. AdjustencoderU phase &back EMFU phase intersection angle for advanced commissioning functions.		
d0.36	Resolver position	1
Resolver position.		
d0.37	Z signal counter	-
d0.38	ABZ position	0.0
ABZ incrementalencoder calculated position information.		
d0.39	V/F target voltage	1V
Target voltage upon V/F separation		
d0.40	V/F output voltage	1V
Output voltage upon V/F separation		
d0.41	Reserved	

4.2 Basic functions group:P0.00-P0.28

Code	Description	Setting range	Default	Restrictions
P0.00	Load type	G type	1	-
		P type	2	

This parameter is used to display the delivered model and cannot be modified.

1: Applicable to constant torque load with rated parameters specified

2: Applicable to variable torque load (fan and pump) with rated parameters specified.

P0.01	Speed control mode	Sensorless flux vector control (SVC)	0	2
		Closed-loop vector control (FVC)	1	
		V/F control	2	

It indicates open-loop vector control, and is applicable to high-performance control applications such as machine tool, centrifuge, wire drawing machine and injection molding machine. One Inverter can operate only one motor.

1: Closed-loop vector control (FVC)

It is applicable to high-accuracy speed control or torque control applications such as high-speed paper making machine, crane and elevator. One Inverter can operate only one motor. An encoder must be installed at the motor side, and a PG card matching the encoder must be installed at the Inverter side.

2: Voltage/Frequency (V/F) control

It is applicable to applications with low load requirements or applications where one Inverter operates multiple motors, such as fan and pump.

Notes:

If vector control is used, motor auto-tuning must be performed because the advantages of vector control can only be utilized after correct motor parameters are obtained. Better performance can be achieved by adjusting speed regulator parameters in group P2.

For the permanent magnetic synchronous motor (PMSM), the DLB1 does not support SVC. FVC is used generally. In some low-power motor applications, you can also use V/F.

DLB2 supports SVC control of PMSM.

P0.02	Command source channel	Operation panel command channel (LED OFF)	0	0
		Terminal command channel (LED ON)	1	
		Communication command channel (LED blinks)	2	

It is used to determine the input channel of the Inverter control commands, such as run, stop, forward rotation, reverse rotation and jog operation. You can input the commands in the following three channels:

0: Operation panel control ("LOCAL" indicator off)

Commands are given by pressing keys on the operation panel.

1: Terminal control ("LOCAL" indicator on)

Commands are given by means of multi-functional input terminals with functions such as FWD, REV, FJOG, and RJOG.

2: Communication control ("LOCAL" indicator blinking)

Commands are given from upper controllers. If this parameter is set to 2, a communication card (Modbus RTU, PROFIBUS-DP card, CANlink card, user programmable card or CANopen card) must be installed.

Can refer to PD group function codes for communications.

P0.03	Main frequency source X selection	Keyboard setting frequency(P0.08, UP/DOWN editable, not retentive at power failure)	0	0
		Keyboard setting frequency(P0.08, UP/DOWN editable, retentive at power failure)	1	
		Analog AI1 setting	2	
		Analog AI2 setting	3	
		AI3(keyboard potentiometer)	4	
		High speed pulse setting(DI5)	5	
		Multi-speed operation setting	6	
		Simple PLC setting	7	
		PID control setting	8	
		Remote communication setting	9	

It is used to select the setting channel of the main frequency X. You can set the main frequency in the following 10 channels:

0: Keyboard setting frequency(P0.08, UP/DOWN editable, not retentive at power failure)

The initial value of the set frequency is the value of P0.08 (Preset frequency). You can change the set frequency by pressing and on the operation panel (or using the UP/DOWN function of input terminals).

When the Inverter is powered on again after power failure, the set frequency reverts to the value of P0.08.

1: Keyboard setting frequency(P0.08, UP/DOWN editable, retentive at power failure)

The initial value of the set frequency is the value of P0.08 (Preset frequency). You can change the set frequency by pressing keys and on the operation panel (or using the UP/DOWN function of input terminals).

When the Inverter is powered on again after power failure, the set frequency is the value memorized at the moment of the last power failure.

Note that P0.10 determines whether the set frequency is memorized or cleared when the Inverter stops. It is related to stop rather than power failure.

2: AI1 (0-10 V voltage input or 4-20 mA current input, determined by jumper J8)

3: AI2 (0-10 V voltage input or 4-20 mA current input, determined by jumper J8)

The frequency is set by analog input. The DLB1 control board provides two analog input (AI) terminals (AI1, AI2).

The DLB1 provides three curves indicating the mapping relationship between the input voltage of AI1 & AI2 and the target frequency. You can set the curves by using function code group P4. When AI is used as the frequency setting source, the corresponding value 100% of the voltage/current input corresponds to the value of P0.10 (Maximum frequency).

4: AI3 (keyboard potentiometer)

5: Pulse setting (DI5)

The frequency is set by DI5 (high-speed pulse). The signal specification of pulse setting is 9-30 V (voltage range) and 0-100 kHz (frequency range). The corresponding value 100% of pulse setting corresponds to the value of P0.10 (Maximum frequency).

6: Multi-speed operation setting

In multi-speed operation setting mode, combinations of different DI terminal states correspond to different set frequencies. The DLB1 supports maximum 16 speeds implemented by 16 state combinations of four DI terminals in Group PC. The multi-speed operation setting indicates percentages of the value of P0.10 (Maximum frequency).

If a DI terminal is used for the multi-speed operation setting, you need to set in group P4.

7: Simple PLC setting

When the simple programmable logic controller (PLC) mode is used as the frequency source, the running frequency of the inverter can be switched over among the 16 frequency references. You can set the holding time and acceleration/deceleration time of the 16 frequency references. For details, refer to the descriptions of Group PC.

8: PID control setting

The output of PID control is used as the running frequency. PID control is generally used in on-site closed-loop control, such as constant pressure closed-loop control and constant tension closed-loop control.

When applying PID as the frequency source, you need to set in group PA.

9: Remote communication setting

The frequency is set by means of communication.

The DLB1 supports four host computer communication protocols: Modbus, PROFIBUS-DP, CANopen and CANlink. They cannot be used simultaneously.

If the communication mode is used, a communication card must be installed. The DLB1 provides four optional communication cards and you can select one based on actual requirements. The corresponding serial communication protocol needs to be selected based on the setting of P0.28.

P0.04	Auxiliary frequency source Y selection	Keyboard setting frequency(P0.08, UP/DOWN editable, not retentive at power failure)	0	0
		Keyboard setting frequency(P0.08, UP/DOWN editable, retentive at power failure)	1	
		Analog AI1 setting	2	
		Analog AI2 setting	3	
		AI3(keyboard potentiometer)	4	
		High speed pulse setting(DI5)	5	
		Multi-speed operation setting	6	
		Simple PLC setting	7	
		PID control setting	8	
		Remote communication setting	9	

When used as an independent frequency input channel (frequency source switched over from X to Y), the auxiliary frequency source Y is used in the same way as the main frequency source X (refer to P0.03).

When the auxiliary frequency source is used for operation (frequency source is "X and Y operation"), pay attention to the following aspects:

- 1) If the auxiliary frequency source Y is digital setting, the preset frequency, P0.08 does not take effect. You can directly adjust the set main frequency by pressing keys and on the operation panel (or using the UP/DOWN function of input terminals).
- 2) If the auxiliary frequency source is analog input (AI1, AI2 and AI3) or pulse setting, 100% of the input corresponds to the range of the auxiliary frequency Y (set in P0.05 and P0.06).
- 3) If the auxiliary frequency source is pulse setting, it is similar to analog input.

The main frequency source X and auxiliary frequency source Y must not use the same channel. That is, P0.03 and P0.04 cannot be set to the same value.

P0.05	Auxiliary frequency Y reference.	Relative to maximum frequency	0	0
		Relative to main frequency source X	1	
P0.06	Range of auxiliary frequency Y for X and Y operation	0%~150%	100%	

If X and Y operation is used, P0.05 and P0.06 are used to set the adjustment range of the auxiliary frequency source.

You can set the auxiliary frequency to be relative to either maximum frequency or main frequency X. If relative to main frequency X, the setting range of the auxiliary frequency Y varies according to the main frequency X.

P0.07	Frequency source combination mode	One's place	Frequency source selection	00
		Main frequency source X	0	
		X and Y operation (operation relationship determined by Ten's place)	1	
		Main frequency source X and Auxiliary frequency source Y switchover	2	
		Switchover between X and "X and Y operation"	3	
		Switchover between X and "Y and Y operation"	4	
		Ten's place	X and Y operation relationship	
		X+Y	0	
		X-Y	1	
		Maximum value	2	
		Minimum value	3	

It is used to select the frequency setting channel, flexibly satisfying various requirements.

P0.08	Keyboard setting frequency	0.00Hz- maximum frequency(valid when frequency source is digital setting)	50.00Hz
-------	----------------------------	---	---------

When frequency source selection is "digital setting" or "terminalUP/DOWN", this value is inverter frequency digital setting initial value.

P0.09	Operation direction selection	Same direction	0	0
		Reverse direction	1	

You can change the rotation direction of the motor just by modifying this parameter without changing the motor wiring. Modifying this parameter is equivalent to exchanging any two of the motor's U, V, W wires.

The motor will resume running in the original direction after parameter initialization. Do not use this function in applications where changing the rotating direction of the motor is prohibited after system commissioning is complete.

P0.10	Maximum output frequency	50.00Hz~320.00Hz	50.00Hz
-------	--------------------------	------------------	---------

When the frequency source is AI, pulse setting (DI5), or multi-reference, 100% of the input corresponds to the value of this parameter.

The output frequency of the DLB1 can reach up to 3200 Hz. To take both frequency reference resolution and frequency input range into consideration, you can set the number of decimal places for frequency reference in P0.22.

- If P0.22 is set to 1, the frequency reference resolution is 0.1 Hz. In this case, the setting range of F0-10 is 50.0 to 3200.0 Hz.
- If P0.22 is set to 2, the frequency reference resolution is 0.01 Hz. In this case, the setting range of F0-10 is 50.00 to 320.00 Hz.

P0.11	Frequency source upper limit	P0.12 setting	0	0
		AI1	1	
		AI2	2	
		AI3(keyboard potentiometer)	3	
		PULSE setting	4	
		Communication setting	5	

It is used to set the source of the frequency upper limit, including digital setting (P0.12), AI, pulse setting or communication setting. If the frequency upper limit is set by means of AI1, AI2, AI3, DI5 or communication, the setting is similar to that of the main frequency source X. For details, see the description of P0.03.

For example, to avoid runaway in torque control mode in winding application, you can set the frequency upper limit by means of analog input. When the inverter reaches the upper limit, it will continue to run at this speed.

P0.12	Frequency upper limit	Frequency lower limit P0.14 to maximum frequency P0.10	50.00Hz
P0.13	Frequency upper limit offset	0.00Hz~ maximum frequency P0.10	0.00Hz

When frequency is set by analog or pulse, P0.13 is used as setting value offset value, and then overlap with P0.11 as final frequency upper limit value.

P0.14	Frequency lower limit	0.00Hz~ upper limit frequency P0.12	0.00Hz
-------	-----------------------	-------------------------------------	--------

If the frequency reference is lower than the value of this parameter, the inverter can stop, run at the frequency lower limit, or run at zero speed, determined by P8.14.

P0.15	Wave carrier frequency setting	0.5kHz~16.0kHz	-
-------	--------------------------------	----------------	---

It is used to adjust the carrier frequency of the inverter, helping to reduce the motor noise, avoiding the resonance of the mechanical system, and reducing the leakage current to the earth and interference generated by the inverter.

If the carrier frequency is low, output current has high harmonics, and the power loss and temperature rise of the motor increase.

If the carrier frequency is high, power loss and temperature rise of the motor declines. However, the inverter has an increase in power loss, temperature rise and interference.

Adjusting the carrier frequency will exert influences on the aspects listed in the following table.

Carrier frequency	Low	High
Motor noise	Big	Small
Output current waveform	Bad	Good
Motor temperature rise	High	Low
Inverter temperature rise	Low	High
Leakage current	Small	Big
External radiation interference	Small	Big

The factory setting of carrier frequency varies with the inverter power. If you need to modify the carrier frequency, note that if the set carrier frequency is higher than factory setting, it will lead to an increase in temperature rise of the inverter's heatsink. In this case, you need to de-rate the inverter. Otherwise, the inverter may overheat and alarm.

P0.16	Carrier frequency adjustment with temperature	No	0	0
		Yes	1	

It is used to set whether the carrier frequency is adjusted based on the temperature. The Inverter automatically reduces the carrier frequency when detecting that the heatsink temperature is high. The Inverter resumes the carrier frequency to the set value when the heatsink temperature becomes normal. This function reduces the overheat alarms.

P0.17	Acceleration time1	0.00s-65000s	-
P0.18	Deceleration time1	0.00s-65000s	-

Acceleration time indicates the time required by the Inverter to accelerate from 0 Hz to "Acceleration/Deceleration base frequency" (P0.25), that is, t_1 in Figure below.

Deceleration time indicates the time required by the Inverter to decelerate from "Acceleration/Deceleration base frequency" (P0.25) to 0 Hz, that is, t_2 in figure below.

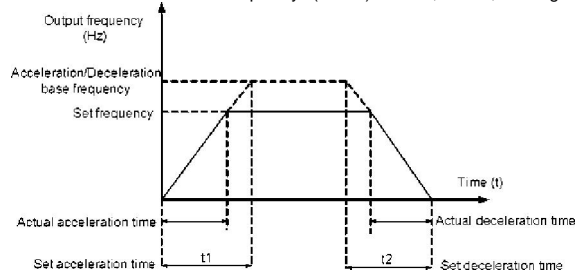

The DLB1 provides totally four groups of acceleration/deceleration time for selection. You can perform switchover by using a DI terminal.

- Group 1: P0.17, P0.18
- Group 2: P8.03, P8.04
- Group 3: P8.05, P8.06
- Group 4: P8.07, P8.08

P0.19	Acceleration/deceleration time unit	1s	0	1
		0.1s	1	
		0.01s	2	

To satisfy requirements of different applications, the DLB1 provides three acceleration/ deceleration time units, 1s, 0.1s and 0.01s.

Modifying this parameter will make the displayed decimal places change and corresponding acceleration/deceleration time also change.

P0.21	Frequency offset of auxiliary frequency source for X and Y operation	0.00Hz~ maximum frequencyP0.10	0.00Hz
-------	--	--------------------------------	--------

This parameter is valid only when the frequency source is set to "X and Y operation".

The final frequency is obtained by adding the frequency offset set in this parameter to the X and Y operation result.

P0.22	Frequency reference resolution	0.1Hz	1	2
		0.01Hz	2	

It is used to set the resolution of all frequency-related parameters.

If the resolution is 0.1 Hz, the DLB1 can output up to 3200 Hz. If the resolution is 0.01 Hz, the DLB1 can output up to 600.00 Hz.

- **Modifying this parameter will make the decimal places of all frequency-related parameters change and corresponding frequency values change.**
- **This parameter is not resumed when factory setting is resumed.**

P0.23	Retentive of digital setting frequency upon power failure	Not retentive	0	0
		Retentive	1	

This parameter is valid only when the frequency source is digital setting.

If P0.23 is set to 0, the digital setting frequency value resumes to the value of P0.08 (Preset frequency) after the Inverter stops. The modification by using keys and or the terminal UP/DOWN function is cleared.

If P0.23 is set to 1, the digital setting frequency value is the set frequency at the moment when the Inverter stops. The modification by using keys and or the terminal UP/ DOWN function remains effective.

P0.25	Acceleration/Deceleration time base frequency	Maximum frequency(P0.10)	0	0
		Set frequency	1	
		100Hz	2	

The acceleration/deceleration time indicates the time for the Inverter to increase from 0 Hz to the frequency set in P0.25. If this parameter is set to 1, the acceleration/deceleration time is related to the set frequency. If the set frequency changes frequently, the motor's acceleration/deceleration also changes.

P0.26	Base frequency for UP/DOWN modification during running	Running frequency	0	0
		Set frequency	1	

This parameter is valid only when the frequency source is digital setting. It is used to set the base frequency to be modified by using keys and or the terminal UP/DOWN function.

If the running frequency and set frequency are different, there will be a large difference between the Inverter's performances during the acceleration/ deceleration process.

P0.27	Binding command source to frequency source	One's place	Binding operation panel command to frequency source	000
		No binding		0
		Frequency source by digital setting		1
		AI1		2
		AI2		3
		AI3(keyboard potentiometer)		4
		Pulse setting(DI5)		5
		Multi-reference instruction		6
		Simple PLC		7
		PID		8
		Communication setting		9
		Ten's place	Binding terminal command to frequency source	
		No binding		0
		Frequency source by digital setting		1
		AI1		2
		AI2		3
		AI3(keyboard potentiometer)		4
		Pulse setting(DI5)		5
		Multi-reference instruction		6

		Simple PLC	7	
		PID	8	
		Communication setting	9	
	Hundred's place	Binding terminal command to frequency source		
		No binding	0	
		Frequency source by digital setting	1	
		AI1	2	
		AI2	3	
		AI3(keyboard potentiometer)	4	
		Pulse setting(DI5)	5	
		Multi-reference instruction	6	
		Simple PLC	7	
		PID	8	
		Communication setting	9	

It is used to bind the three running command sources with the nine frequency sources, facilitating to implement synchronous switchover.

For details on the frequency sources, see the description of P0.03 (Main frequency source X selection). Different running command sources can be bound to the same frequency source.

If a command source has a bound frequency source, the frequency source set in P0.03 to P0.07 no longer takes effect when the command source is effective.

P0.28	Communication card type	Modbus communication card	0	0
		Profibus-DP communication card	1	
		CANopen communication card	2	
		CANlink communication card	3	

DLB1 provides two communication modes. Both need choose compatible communicationcard. Only one communication card can be used at the same time.

4.3 First motor parameters:P1.00-P1.37

Code	Description	Setting range	Default	Restrictions
P1.00	Motor type selection	Common asynchronous motor	0	0
		Variable frequency asynchronous motor	1	
		Permanent magnetic synchronous motor	2	
P1.01	Motor rated power	0.1kW~1000.0kW	-	
P1.02	Motor rated voltage	1V~2000V	-	
P1.03	Motor rated current	0.01A~655.35A(inverter rated power ≤55kW) 0.1A~6553.5A(inverter rated power >55kW)	-	
P1.04	Motor rated frequency	0.01Hz~ maximum frequency	-	
P1.05	Motor rated speed	1rpm~65535rpm	-	

Set the parameters according to the motor nameplate no matter whether V/F control or vector control is adopted.

To achieve better V/F or vector control performance, motor auto-tuning is required. The motor auto-tuning accuracy depends on the correct setting of motor nameplate parameters.

P1.06	Asynchronous motor stator resistance	0.001 ~65.535 (inverter power≤55kW) 0.0001 ~6.5535 (inverter power>55kW)	-	
P1.07	Asynchronous motor rotor resistance	0.001 ~65.535 (inverter power≤55kW) 0.0001 ~6.5535 (inverter power>55kW)	-	
P1.08	Asynchronous motor leakage inductive reactance	0.01mH~655.35mH(inverter power≤55kW) 0.001mH~65.535mH(inverter power>55kW)	-	
P1.09	Asynchronous motor mutual inductive reactance	0.1mH~6553.5mH(inverter power≤55kW) 0.01mH~655.35mH(inverter power>55kW)	-	
P1.10	Asynchronous motor no load current	0.01A~P1.03(inverter power≤55kW) 0.1A~P1.03(inverter power>55kW)	-	

The parameters in P1.06 to P1.10 are asynchronous motor parameters. These parameters are unavailable on the motor nameplate and are obtained by motor auto-tuning. Only P1.06 to P1.08 can be obtained through static motor auto-tuning. Through complete motor auto-tuning, encoder phase sequence and current loop PI can be obtained besides the parameters in P1.06 to P1.10.

Each time "Motor rated power" (P1.01) or "Motor rated voltage" (P1.02) is changed, the Inverter automatically restores values of P1.06 to P1.10 to the parameter setting for the common standard Y series asynchronous motor.

If it is impossible to perform motor auto-tuning onsite, manually input the values of these parameters according to data provided by the motor manufacturer.

P1.16	Synchronous motor stator resistance	0.001 ~65.535 (inverter power<=55kW) 0.0001 ~6.5535 (inverter power>55kW)	-	
P1.17	Synchronous motor shaft D inductance	0.01mH~655.35mH(inverter power<=55kW) 0.001mH~65.535mH(inverter power>55kW)	-	
P1.18	Synchronous motor shaft Q inductance	0.01mH~655.35mH(inverter power<=55kW) 0.001mH~65.535mH(inverter power>55kW)	-	
P1.19	Inductance resistance unit	0~12	0	
P1.20	Back EMF coefficient	0.1V~6553.5V	0.1V	
P1.21	Phase loss detection time	0~60000	0	

P1.16 to P1.21 are synchronous motor parameters. These parameters are unavailable on the nameplate of most synchronous motors and can be obtained by means of "Synchronous motor no-load auto-tuning". Through "Synchronous motor with-load auto-tuning", only the encoder phase sequence and installation angle can be obtained.

Each time "Rated motor power" (P1.01) or "Rated motor voltage" (P1.02) is changed, the Inverter automatically modifies the values of P1.16 to P1.20.

You can also directly set the parameters based on the data provided by the synchronous motor manufacturer.

P1.27	Encoder pulse per revolution	1~65535	2500	
-------	------------------------------	---------	------	--

This parameter is used to set the pulses per revolution (PPR) of ABZ or UWW incremental encoder. In FVC mode, the motor cannot run properly if this parameter is set incorrectly.

P1.28	Encoder type	ABZ incremental encoder	0	0
		UWW incremental encoder	1	
		Resolver	2	
		Sin-cos encoder	3	
		Line-saving UWWencoder	4	

The DLB1 supports multiple types of encoder. Different PG cards are required for different types of encoder. Select the appropriate PG card for the encoder used. Any of the five encoder types is applicable to synchronous motor. Only ABZ incremental encoder and resolver are applicable to asynchronous motor.

After installation of the PG card is complete, set this parameter properly based on the actual condition. Otherwise, the Inverter cannot run properly.

P1.30	A/B phase sequence of ABZ incremental encoder	Forward	0	0
		Reverse	1	

This parameter is valid only for ABZ incremental encoder (P1.28 = 0) and is used to set the A/B phase sequence of the ABZ incremental encoder.

It is valid for both asynchronous motor and synchronous motor. The A/B phase sequence can be obtained through "Asynchronous motor complete auto-tuning" or "Synchronous motor no-load auto-tuning".

P1.31	Encoder installation angle	0°~359.9°	0.00
-------	----------------------------	-----------	------

This parameter is applicable only to synchronous motor. It is valid for ABZ incremental encoder, UVW incremental encoder, resolver and wire-saving UVW encoder, but invalid for SIN/COS encoder.

It can be obtained through synchronous motor no-load auto-tuning or with-load auto-tuning. After installation of the synchronous motor is complete, the value of this parameter must be obtained by motor auto-tuning. Otherwise, the motor cannot run properly.

P1.32	U, V, W phase sequence of UVW encoder	Forward	0	0
		Reverse	1	
P1.33	UVW encoder angle offset	0.0°~359.9°	0.00	

These two parameters are valid only when the UVW encoder is applied to a synchronous motor.

They can be obtained by synchronous motor no-load auto-tuning or with-load auto-tuning. After installation of the synchronous motor is complete, the values of these two parameters must be obtained by motor auto-tuning. Otherwise, the motor cannot run properly.

P1.34	Resolver pole pairs	1~65535	1
P1.35	UVW pole pairs	1~65535	4
P1.36	Encoder wire-break fault detection time	0.0s:No action; 0.1s~10.0s	0.0s

This parameter is used to set the time that a wire-break fault lasts.

If it is set to 0.0s, the Inverter does not detect the encoder wire-break fault.

If the duration of the encoder wire-break fault detected by the Inverter exceeds the time set in this parameter, the Inverter reports Err20.

P1.37	Auto-tuning selection	No auto-tuning	0	0
		Asynchronous motor static auto-tuning	1	
		Asynchronous motor complete auto-tuning	2	
		Synchronous motor static auto-tuning	11	
		Synchronous motor complete auto-tuning	12	

-
- 0: No auto-tuning: Auto-tuning is prohibited.

- 1: Asynchronous motor static auto-tuning

It is applicable to scenarios where complete auto-tuning cannot be performed because the asynchronous motor cannot be disconnected from the load.

Before performing static auto-tuning, properly set the motor type and motor nameplate parameters of P1.00 to P1.05 first. The Inverter will obtain parameters of P1.06 to P1.08 by static auto-tuning. Set this parameter to 1, and press RUN. Then, the Inverter starts static auto-tuning.

- 2: Asynchronous motor complete auto-tuning

To perform this type of auto-tuning, ensure that the motor is disconnected from the load. During the process of complete auto-tuning, the Inverter performs static auto-tuning first and then accelerates to 80% of the rated motor frequency within the acceleration time set in P0.17. The Inverter keeps running for a certain period and then decelerates to stop within deceleration time set in P0.18.

Before performing complete auto-tuning, properly set the motor type, motor nameplate parameters of P1.00 to P1.05, "Encoder type" (P1.28) and "Encoder pulses per revolution" (P1.27) first.

The Inverter will obtain motor parameters of P1.06 to P1.10, "A/B phase sequence of ABZ incremental encoder" (P1.30) and vector control current loop PI parameters of P3.13 to P3.16 by complete auto-tuning.

Set this parameter to 2, and press RUN. Then, the Inverter starts complete auto-tuning.

- 11: Synchronous motor with-load auto-tuning

It is applicable to scenarios where the synchronous motor cannot be disconnected from the load. During with-load auto-tuning, the motor rotates at the speed of 10 PRM.

Before performing with-load auto-tuning, properly set the motor type and motor nameplate parameters of P1.00 to P1.05 first.

By with-load auto-tuning, the Inverter obtains the initial position angle of the synchronous motor, which is a necessary prerequisite of the motor's normal running. Before the first use of the synchronous motor after installation, motor auto-tuning must be performed.

Set this parameter to 11, and press RUN. Then, the Inverter starts with-load auto-tuning.

- 12: Synchronous motor no-load auto-tuning

If the synchronous motor can be disconnected from the load, no-load auto-tuning is recommended, which will achieve better running performance compared with with-load auto-tuning.

During the process of no-load auto-tuning, the Inverter performs with-load auto-tuning first and then accelerates to 80% of the rated motor frequency within the acceleration time set in P0.17. The Inverter keeps running for a certain period and then decelerates to stop within the deceleration time set in P0.18.

Before performing no-load auto-tuning, properly set the motor type, motor nameplate parameters of P1.00 to P1.05, "Encoder type" (P1.28) and "Encoder pulses per revolution" (P1.27) and "Number of pole pairs of resolver" (P1.34) first.

The Inverter will obtain motor parameters of P1.16 to P1.20, encoder related parameters of P1.30 to P1.33 and vector control current loop PI parameters of P3.13 to P3.16 by no-load auto-tuning.

Set this parameter to 12, and press RUN. Then, the Inverter starts no-load auto-tuning.

Motor auto-tuning can be performed only in operation panel mode.

4.4 V/F control parameters:P2.00-P2.15

Group P2 is valid only for V/F control.

The V/F control mode is applicable to low load applications (fan or pump) or applications where one Inverter operates multiple motors or there is a large difference between the Inverter power and the motor power.

Code	Description	Setting range	Default	Restrictions	
P2.00	V/F curve setting	Linear V/F	0	0	
		Multi-point V/F	1		
		Square V/F	2		
		1.2 time V/F	3		
		1.4 time V/F	4		
		1.5 time V/F	5		
		1.6 time V/F	6		
		1.7 time V/F	7		
		1.8 time V/F	8		
		Reserved	9		
		VF complete separation mode	10		
		VF half separation mode	11		
		Hundred's place	No automatic voltage regulation function		0
			Have automatic voltage regulation function		1
			Have automatic voltage regulation function, but not during decelerations.		2

One's place, Ten's place:V/F mode

- 0: Linear V/F

It is applicable to common constant torque load.

- 1: Multi-point V/F

It is applicable to special load such as dehydrator and centrifuge. Any such V/F curve can be obtained by setting parameters of P2.03 to P2.08.

- 2: Square V/F

It is applicable to centrifugal loads such as fan and pump.

- 3 to 8: V/F curve between linear V/F and square V/F
- 10: V/F complete separation

In this mode, the output frequency and output voltage of the Inverter are independent. The output frequency is determined by the frequency source, and the output voltage is determined by "Voltage source for V/F separation" (P2.13).

It is applicable to induction heating, inverse power supply and torque motor control.

- 11: V/F half separation

In this mode, V and F are proportional and the proportional relationship can be set in P2.13. The relationship between V and F are also related to the rated motor voltage and rated motor frequency in Group F1.

Assume that the voltage source input is X (0 to 100%), the relationship between V and F is:
 $V/F = 2 * X * (\text{Rated motor voltage}) / (\text{Rated motor frequency})$

Hundred's place: automatic voltage regulation (AVR) function

CPU automatically optimizes DC bus voltage when grid power supply fluctuates..

0: No AVR;

1: Have AVR;

2: Have AVR but not during deceleration.

P2.01	Torque boost	0.0%~30%	-	
P2.02	Torque boost cut-off frequency	0.00Hz~ maximum output frequency	50.00Hz	

To compensate the low frequency torque characteristics of V/F control, you can boost the output voltage of the Inverter at low frequency by modifying P2.01.

If the torque boost is set to too large, the motor may overheat, and the Inverter may suffer overcurrent.

If the load is large and the motor startup torque is insufficient, increase the value of P2.01. If the load is small, decrease the value of P2.01. If it is set to 0.0, the Inverter performs automatic torque boost. In this case, the Inverter automatically calculates the torque boost value based on motor parameters including the stator resistance.

P2.02 specifies the frequency under which torque boost is valid. Torque boost becomes invalid when this frequency is exceeded.

P2.03	Multi-point V/F frequency 1 (F1)	0.00Hz~P2.05	0.00Hz	
P2.04	Multi-point V/F voltage 1 (V1)	0.0%~100.0%	0.0%	
P2.05	Multi-point V/F frequency 2 (F2)	P2.03~P2.07	0.00Hz	
P2.06	Multi-point V/F voltage 2 (V2)	0.0%~100.0%	0.0%	
P2.07	Multi-point V/F frequency 3 (F3)	P2.05~ motorrated 频(P1.04)	0.00Hz	
P2.08	Multi-point V/F voltage 3 (V3)	0.0%~100.0%	0.0%	

These six parameters are used to define the multi-point V/F curve.

The multi-point V/F curve is set based on the motor's load characteristic. The relationship between voltages and frequencies is:

$$V1 < V2 < V3, F1 < F2 < F3$$

At low frequency, higher voltage may cause overheat or even burnt out of the motor and overcurrent stall or overcurrent protection of the Inverter.

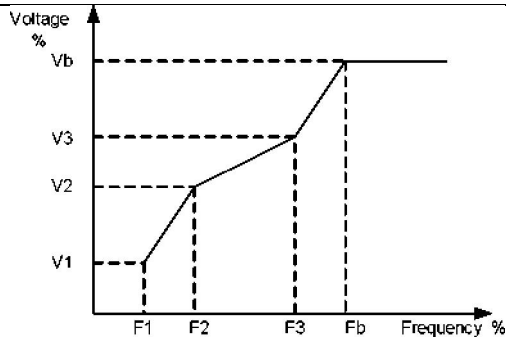

V1-V3: 1st, 2nd and 3rd voltage percentages of multi-point V/F
 P1.F3: 1st, 2nd and 3rd frequency percentages of multi-point V/F
 Vb: Rated motor voltage
 Fb: Rated motor running frequency

P2.09	V/F slip compensation gain	0%~200.0%	0.0%	
-------	----------------------------	-----------	------	--

This parameter is valid only for the asynchronous motor.

It can compensate the rotational speed slip of the asynchronous motor when the load of the motor increases, stabilizing the motor speed in case of load change.

If this parameter is set to 100%, it indicates that the compensation when the motor bears rated load is the rated motor slip. The rated motor slip is automatically obtained by the Inverter through calculation based on the rated motor frequency and rated motor rotational speed in group P1.

Generally, if the motor rotational speed is different from the target speed, slightly adjust this parameter.

P2.10	V/F over-excitation gain	0~200	64	
-------	--------------------------	-------	----	--

During deceleration of the Inverter, over-excitation can restrain rise of the bus voltage, preventing the overvoltage fault. The larger the over-excitation is, the better the restraining result is.

Increase the over-excitation gain if the Inverter is liable to overvoltage error during deceleration. However, too large over-excitation gain may lead to an increase in the output current. Set P2.09 to a proper value in actual applications.

Set the over-excitation gain to 0 in the applications where the inertia is small and the bus voltage will not rise during motor deceleration or where there is a braking resistor.

P2.11	V/F oscillation suppression gain	0~100	-	
-------	----------------------------------	-------	---	--

Set this parameter to a value as small as possible in the prerequisite of efficient oscillation suppression to avoid influence on V/F control.

Set this parameter to 0 if the motor has no oscillation. Increase the value properly only when the motor has obvious oscillation. The larger the value is, the better the oscillation suppression result will be.

When the oscillation suppression function is enabled, the rated motor current and no-load current must be correct. Otherwise, the V/F oscillation suppression effect will not be satisfactory.

P2.13	Voltage source for V/Fseparation	Digital setting(P2.14)	0	0
		AI1	1	
		AI2	2	
		AI3(keyboard potentiometer)	3	
		Pulse setting(DI5)	4	
		Multi-reference	5	
		Simple PLC	6	
		PID	7	
		Communication	8	
		100.0% corresponding to motorrated voltage(P1.02)		
P2.14	Voltage digital setting for V/F separation	0V~ motorrated voltage	0V	

V/F separation is generally applicable to scenarios such as induction heating, inverse power supply and motor torque control.

If V/F separated control is enabled, the output voltage can be set in P2.14 or by means of analog, multi-reference, simple PLC, PID or communication. If you set the output voltage by means of non-digital setting, 100% of the setting corresponds to the motor rated voltage. If a negative percentage is set, its absolute value is used as the effective value.

- 0: Digital setting (P2.14)

The output voltage is set directly in P2.14.

- 1: AI1; 2: AI2; 3: AI3

The output voltage is set by AI terminals.

- 4: Pulse setting (DI5)

The output voltage is set by pulses of the terminal D | 5.

Pulse setting specification: voltage range 9-30 V, frequency range 0-100 kHz

- 5: Multi-reference

If the voltage source is multi-reference, parameters in group P4 and PC must be set to determine the corresponding relationship between setting signal and setting voltage. 100.0% of the multi-reference setting in group PC corresponds to the rated motor voltage.

- 6: Simple PLC

If the voltage source is simple PLC mode, parameters in group PC must be set to determine the setting output voltage.

- 7: PID

The output voltage is generated based on PID closed loop. For details, see the description of PID in group PA.

- 8: Communication setting

The output voltage is set by the host computer by means of communication.

The voltage source for V/F separation is set in the same way as the frequency source. For details, see P0.03. 100.0% of the setting in each mode corresponds to the rated motor voltage. If the corresponding value is negative, its absolute value is used.

P2.15	Voltage rise time of V/F separation	0.0s~1000.0s	0.0s	
P2.16	Voltage decline time of V/F separation	0.0s~1000.0s	0.0s	

P2.15 indicates the time required for the output voltage to rise from 0 V to the rated motor voltage shown as t1 in the following figure.

P2.16 indicates the time required for the output voltage to decline from the rated motor voltage to 0 V, shown as t2 in the following figure.

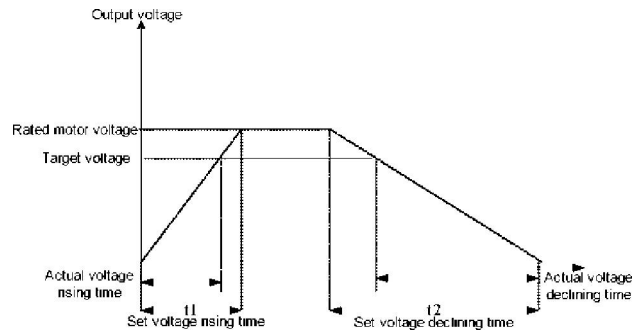

4.5 Vector control parameters:P3.00-P3.22

P3 group is valid for vector control, and invalid for V/F control.

Code	Description	Setting range	Default	Restrictions
P3.00	Speed loop proportional gain 1	1~100	30	
P3.01	Speed loop integral time 1	0.01s~10.00s	0.50s	
P3.02	Switchover frequency 1	0.00~P3.05	5.00Hz	
P3.03	Speed loop proportional gain 2	0~100	20	
P3.04	Speed loop integral time 2	0.01s~10.00s	1.00s	
P3.05	Switchover frequency 2	P3.02~ maximum output frequency	10.00Hz	

Speed loop PI parameters vary with running frequencies of the Inverter.

- If the running frequency is less than or equal to "Switchover frequency 1" (P3.02), the speed loop PI parameters are P3.00 and P3.01.
- If the running frequency is equal to or greater than "Switchover frequency 2" (P3.05), the speed loop PI parameters are P3.03 and P3.04.
- If the running frequency is between P3.02 and P3.05, the speed loop PI parameters are obtained from the linear switchover between the two groups of PI parameters, as shown in Figure below.

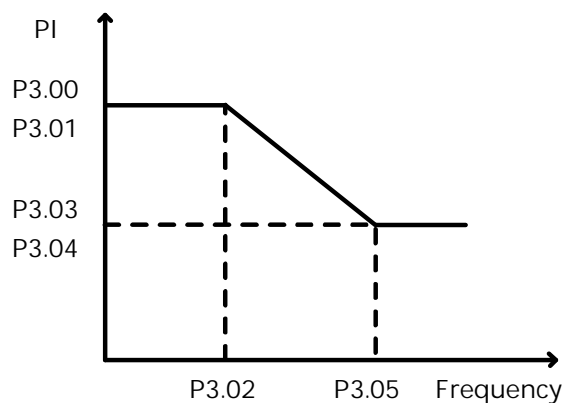

Graph 4-5 PI parameters

The speed dynamic response characteristics in vector control can be adjusted by setting the proportional gain and integral time of the speed regulator.

To achieve a faster system response, increase the proportional gain and reduce the integral time. Be

aware that this may lead to system oscillation.

The recommended adjustment method is as follows:

If the factory setting cannot meet the requirements, make proper adjustment. Increase the proportional gain first to ensure that the system does not oscillate, and then reduce the integral time to ensure that the system has quick response and small overshoot.

Improper PI parameter setting may cause too large speed overshoot, and overvoltage fault may even occur when the overshoot drops.

P3.06	Vector control slip gain	50%~200%	150%	
-------	--------------------------	----------	------	--

For SVC, it is used to adjust speed stability accuracy of the motor. When the motor with load runs at a very low speed, increase the value of this parameter; when the motor with load runs at a very large speed, decrease the value of this parameter.

For FVC, it is used to adjust the output current of the Inverter with same load.

P3.07	Time constant of speed loop filter	0.000s~0.100s	0.000s	
-------	------------------------------------	---------------	--------	--

In the vector control mode, the output of the speed loop regulator is torque current reference. This parameter is used to filter the torque references. It need not be adjusted generally and can be increased in the case of large speed fluctuation. In the case of motor oscillation, decrease the value of this parameter properly.

If the value of this parameter is small, the output torque of the Inverter may fluctuate greatly, but the response is quick.

P3.08	Vector control over-excitation gain	0~200	64	
-------	-------------------------------------	-------	----	--

During deceleration of the Inverter, over-excitation control can restrain rise of the bus voltage to avoid the overvoltage fault. The larger the over-excitation gain is, the better the restraining effect is.

Increase the over-excitation gain if the Inverter is liable to overvoltage error during deceleration. Too large over-excitation gain, however, may lead to an increase in output current. Therefore, set this parameter to a proper value in actual applications.

Set the over-excitation gain to 0 in applications of small inertia (the bus voltage will not rise during deceleration) or where there is a braking resistor.

P3.09	Torque upper limit source in speed control mode	P3.10	0	0
		A11	1	
		A12	2	

		AI3(keyboard potentiometer)	3	
		Pulse setting	4	
		Communication setting	5	
		Min(AI1, AI2)	6	
		Max(AI1, AI2)	7	
P3.10	Digital setting of torque upper limit in speed control mode	0.0%~200.0%	150.0%	

In the speed control mode, the maximum output torque of the Inverter is restricted by P3.09. If the torque upper limit is analog, pulse or communication setting, 100% of the setting corresponds to the value of P3.10, and 100% of the value of P3.10 corresponds to the Inverter rated torque.

P3.13	Excitation adjustment proportional gain	0~60000	2000	
P3.14	Excitation adjustment integral gain	0~60000	1300	
P3.15	Torque adjustment proportional gain	0~60000	2000	
P3.16	Torque adjustment integral gain	0~60000	1300	

These are current loop PI parameters for vector control. These parameters are automatically obtained through "Asynchronous motor complete auto-tuning" or "Synchronous motor no-load auto-tuning", and need not be modified.

The dimension of the current loop integral regulator is integral gain rather than integral time.

Note that too large current loop PI gain may lead to oscillation of the entire control loop. Therefore, when current oscillation or torque fluctuation is great, manually decrease the proportional gain or integral gain here.

P3.17	Speed loop integral	One's place	Invalid	0	0
			Valid	1	
P3.18	Field weakening mode of synchronous motor	No field weakening	0	1	
		Direct calculating	1		
		Automatic adjustment mode	2		
P3.19	Field weakening depth of synchronous motor	50%~500%	100%		
P3.20	Maximum field weakening current	1%~300%	50%		
P3.21	Field weakening automatic adjustment gain	10%~500%	100%		

P3.22	Field weakening integral multiple	2~10	2	
-------	-----------------------------------	------	---	--

These parameters are used to set field weakening control for the synchronous motor.

If P3.18 is set to 0, field weakening control on the synchronous motor is disabled. In this case, the maximum rotational speed is related to the Inverter bus voltage. If the motor's maximum rotational speed cannot meet the requirements, enable the field weakening function to increase the speed.

The DLB1 provides two field weakening modes: direct calculation and automatic adjustment.

- In direct calculation mode, directly calculate the demagnetized current and manually adjust the demagnetized current by means of P3.19. The smaller the demagnetized current is, the smaller the total output current is. However, the desired field weakening effect may not be achieved.

- In automatic adjustment mode, the best demagnetized current is selected automatically. This may influence the system dynamic performance or cause instability.

The adjustment speed of the field weakening current can be changed by modifying the values of P3.21 and P3.22. A very quick adjustment may cause instability. Therefore, generally do not modify them manually.

4.6 Input terminals:P4.00-P4.39

The DLB1 provides six DI terminals (DI5 can be used for high-speed pulse input) and three analog input (AI) terminals. The optional extension card provides another four DI terminals (DI7 to DI10) and an AI terminal (AI3x).

Code	Description	Setting range	Default	Restrictions
P4.00	DI1 function selection	0~59	1	
P4.01	DI2 function selection	0~59	4	
P4.02	DI3 function selection	0~59	9	
P4.03	DI4 function selection	0~59	12	
P4.04	DI5 function selection	0~59	13	
P4.05	DI6 function selection	0~59	2	
P4.06	DI7 function selection	0~59	12	
P4.07	DI8 function selection	0~59	13	
P4.08	DI9 function selection	0~59	14	
P4.09	DI10 function selection	0~59	15	

The following table lists the functions available for the DI terminals.

Value	Function	Description
0	No function	Set 0 for reserved terminals to avoid malfunction.
1	Forward RUN (FWD)	The terminal is used to control forward or reverse RUN of the Inverter.
2	Reverse RUN (REV)	
3	Three-line control	The terminal determines three-line control of the Inverter. For details, see the description of P4.11.
4	Forward JOG (FJOG)	FJOG indicates forward JOG running, while RJOG indicates reverse JOG running. The JOG frequency, acceleration time and deceleration time are described respectively in P8.00, P8.01 and P8.02.
5	Reverse JOG (RJOG)	
6	Terminal UP	If the frequency is determined by external terminals, the terminals with the two functions are used as increment and decrement commands for frequency modification. When the frequency source is digital setting, they are used to adjust the frequency.
7	Terminal DOWN	
8	Coast to stop	The Inverter blocks its output, the motor coasts to rest and is not controlled by the Inverter. It is the same as coast to stop described in P6.10.
9	Fault reset (RESET)	The terminal is used for fault reset function, the same as the function of RESET key on the operation panel. Remote fault reset is implemented by this function.

10	RUN pause	The Inverter decelerates to stop, but the running parameters are all memorized, such as PLC, swing frequency and PID parameters. After this function is disabled, the Inverter resumes its status before stop.
11	Normally open (NO) input of external fault	If this terminal becomes ON, the Inverter reports 15=E.IOF and performs the fault protection action. For more details, see the description of P9.47.
12	Multi-reference terminal 1	The setting of 16 speeds or 16 other references can be implemented through combinations of 16 states of these four terminals.
13	Multi-reference terminal 2	
14	Multi-reference terminal 3	
15	Multi-reference terminal 4	
16	Terminal 1 for acceleration/ deceleration time selection	Totally four groups of acceleration/deceleration time can be selected through combinations of two states of these two terminals.
17	Terminal 2 for acceleration/ deceleration time selection	
18	Frequency source switchover	The terminal is used to perform switchover between two frequency sources according to the setting in P0.07.
19	UP and DOWN setting clear (terminal, operation panel)	If the frequency source is digital setting, the terminal is used to clear the modification by using the UP/ DOWN function or the increment/decrement key on the operation panel, returning the set frequency to the value of P0.08.
20	Command source switchover terminal	If the command source is set to terminal control (P0.02 = 1), this terminal is used to perform switchover between terminal control and operation panel control. If the command source is set to communication control (P0.02 = 2), this terminal is used to perform switchover between communication control and operation panel control.
21	Acceleration/Deceleration prohibited	It enables the Inverter to maintain the current frequency output without being affected by external signals (except the STOP command).
22	PID pause	PID is invalid temporarily. The Inverter maintains the current frequency output without supporting PID adjustment of frequency source.
23	PLC status reset	The terminal is used to restore the original status of PLC control for the Inverter when PLC control is started again after a pause.
24	Swing pause	The Inverter outputs the central frequency, and the swing frequency function pauses.
25	Counter input	This terminal is used to count pulses.
26	Counter reset	This terminal is used to clear the counter status.
27	Length count input	This terminal is used to count the length.

28	Length reset	This terminal is used to clear the length.
29	Torque control prohibited	The Inverter is prohibited from torque control and enters the speed control mode.
30	Pulse input (enabled only for DI5)	DI5 is used for pulse input.
31	Reserved	Reserved.
32	Immediate DC braking	After this terminal becomes ON, the Inverter directly switches over to the DC braking state.
33	Normally closed (NC) input of external fault	After this terminal becomes ON, the Inverter reports 15=E.EIOF and stops.
34	Frequency modification	After this terminal becomes ON, the Inverter does not respond to any frequency modification.
35	Reverse PID action direction	After this terminal becomes ON, the PID action direction is reversed to the direction set in PA.03.
36	External STOP terminal 1	In operation panel mode, this terminal can be used to stop the Inverter, equivalent to the function of the STOP key on the operation panel.
37	Command source switchover terminal 2	It is used to perform switchover between terminal control and communication control. If the command source is terminal control, the system will switch over to communication control after this terminal becomes ON.
38	PID integral pause	After this terminal becomes ON, the integral adjustment function pauses. However, the proportional and differentiation adjustment functions are still valid.
39	Switchover between main frequency source X and preset frequency	After this terminal becomes ON, the frequency source X is replaced by the preset frequency set in P0.08.
40	Switchover between auxiliary frequency source Y and preset frequency	After this terminal is enabled, the frequency source Y is replaced by the preset frequency set in P0.08.
41	Reserved	Reserved
42	Reserved	
43	PID parameter switchover	If the PID parameters switchover performed by means of DI terminal (PA.18 = 1), the PID parameters are PA.05 to PA.07 when the terminal becomes OFF; the PID parameters are PA.15 to PA.17 when this terminal becomes ON.
44	User-defined fault 1	If these two terminals become ON, the Inverter reports 27=E.USt1 and 28=E.USt2 respectively, and performs fault protection actions based on the setting in P9.49.
45	User-defined fault 2	
46	Speed control/Torque control switchover	This terminal enables the Inverter to switch over between speed control and torque control. When this terminal becomes OFF, the Inverter runs in the mode set in b0.00. When this terminal becomes ON, the Inverter switches over to the other control mode.

47	Emergency stop	When this terminal becomes ON, the Inverter stops within the shortest time. During the stop process, the current remains at the set current upper limit. This function is used to satisfy the requirement of stopping the Inverter in emergency state.
48	External STOP terminal 2	In any control mode (operation panel, terminal or communication), it can be used to make the Inverter decelerate to stop. In this case, the deceleration time is deceleration time 4.
49	Deceleration DC braking	When this terminal becomes ON, the Inverter decelerates to the initial frequency of stop DC braking and then switches over to DC braking state.
50	Clear the current running time	When this terminal becomes ON, the Inverter's current running time is cleared. This function must be supported by P8.42 and P8.53.
51-59	Reserved	Reserved

The four multi-reference terminals have 16 state combinations, corresponding to 16 reference values, as listed in the following table.

K ₄	K ₃	K ₂	K ₁	Reference setting	Corresponding parameter
OFF	OFF	OFF	OFF	Reference 0	PC.00
OFF	OFF	OFF	ON	Reference 1	PC.01
OFF	OFF	ON	OFF	Reference 2	PC.02
OFF	OFF	ON	ON	Reference 3	PC.03
OFF	ON	OFF	OFF	Reference 4	PC.04
OFF	ON	OFF	ON	Reference 5	PC.05
OFF	ON	ON	OFF	Reference 6	PC.06
OFF	ON	ON	ON	Reference 7	PC.07
ON	OFF	OFF	OFF	Reference 8	PC.08
ON	OFF	OFF	ON	Reference 9	PC.09
ON	OFF	ON	OFF	Reference 10	PC.10
ON	OFF	ON	ON	Reference 11	PC.11
ON	ON	OFF	OFF	Reference 12	PC.12
ON	ON	OFF	ON	Reference 13	PC.13
ON	ON	ON	OFF	Reference 14	PC.14
ON	ON	ON	ON	Reference 15	PC.15

If the frequency source is multi-reference, the value 100% of FC-00 to FC-15 corresponds to the value of P0.10 (Maximum frequency).

Besides the multi-speed function, the multi-reference can be also used as the PID setting source or the voltage source for V/F separation, satisfying the requirement on switchover of different setting values.

Two terminals for acceleration/deceleration time selection have four state combinations, as listed in the following table.

Terminal 2	Terminal 1	Acceleration/ deceleration time selection	Corresponding parameter
OFF	OFF	Acceleration/Deceleration time 1	P0.17, P0.18
OFF	ON	Acceleration/Deceleration time 2	P8.03, P8.04
ON	OFF	Acceleration/Deceleration time 3	P8.05, P8.06
ON	ON	Acceleration/Deceleration time 4	P8.07, P8.08

P4.10	DI filter time	0.000s~1.000s	0.010s
-------	----------------	---------------	--------

It is used to set the software filter time of DI terminal status. If DI terminals are liable to interference and may cause malfunction, increase the value of this parameter to enhance the anti-interference capability. However, increase of DI filter time will reduce the response of DI terminals.

P4.11	Terminal command mode	One's place	Terminal command mode		00
		Two-line mode 1		0	
		Two-line mode 2		1	
		Three-line mode 1		2	
		Three-line mode 2		3	
		Two-line mode 1		4	
		Three-line mode 2		5	
		Ten's place	Terminal input priority		
		JOG overrides FWD, REV		0	
		FWD, REV override JOG		1	

One's place:

This parameter sets the mode in which the Inverter is controlled by external terminals.

0:Two-line mode 1;

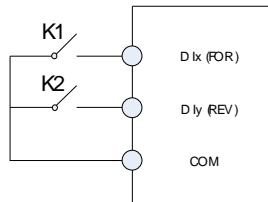

It is the most commonly used two-line mode, in which the forward/reverse rotation of the motor is decided by D1x and Dly. The parameters are set as below:

Value	Function	Description
D1x	1	Forward operation(FWD)
Dly	2	Reverse operation(REV)

As shown in the below figure, when only K1 is ON, the Inverter instructs forward rotation. When only K2 is ON, the Inverter instructs reverse rotation. When K1 and K2 are ON or OFF simultaneously, the Inverter stops.

K1	K2	Operation
0	0	Stop
0	1	REV
1	0	FWD
1	1	Stop

1:Two-line mode 2;

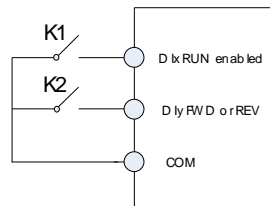

In this mode, D1x is enable terminal, and Dly terminal decides operation direction .

Value	Function	Description
D1x	1	Forward operation(FWD)
Dly	2	Reverse operation(REV)

0: invalid; 1: valid.

K1	K2	Operation
0	0	Stop
0	1	Stop
1	0	FWD
1	1	REV

2:Three-line mode 1;

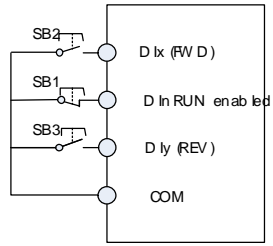

SB1:Stop button
 SB2:FWD button
 SB3: REV button

In this mode, Dln is enable terminal, and Dlx & Dly terminal decides operation direction .

Value	Function	Description
Dlx	1	Forward operation(FWD)
Dly	2	Reverse operation(REV)
Dln	3	RUN enabled

0: invalid; 1: valid; X: random.

SB1	SB2	SB3	Operation
0	X	X	Stop
1	1	0	FWD
1	0	1	REV
1	1	0->1	REV
1	0->1	1	FWD

3:Three-line mode 2;

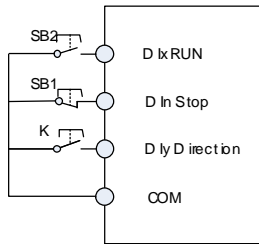

SB1:Stop button
 SB2:Run button

In this mode, DI_n is enable terminal, DI_x is RUN terminal and DI_y terminal decides operation direction .

Value	Function	Description
DI _x	1	RUN
DI _y	2	Direction
DI _n	3	Enable

0: invalid; 1: valid; X: random.

SB1	SB2	K	Operation
0	X	X	Stop
1	1	0	FWD
1	1	1	REV

4 Two-line mode 3;

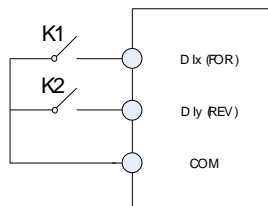

In this mode, the earlier valid terminals have priorities.

Value	Function	Description
DI _x	1	Forward operation(FWD)
DI _y	2	Reverse operation(REV)

0: invalid; 1: valid.

K1	K2	Operation
0	0	Stop
0	1	REV
1	0	FWD
1	0->1	FWD
0->1	1	REV

5: Three-line mode 3;

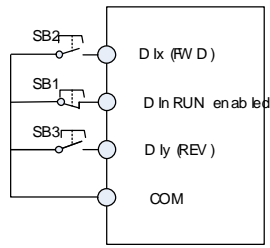

SB1: Stop button
 SB2: FWD button
 SB3: REV button

In this mode, the earlier valid terminals have priorities.

Value	Function	Description
Dlx	1	Forward operation(FWD)
Dly	2	Reverse operation(REV)
Dln	3	RUN enabled

0: invalid; 1: valid; X: random.

SB1	SB2	SB3	Operation
0	X	X	Stop
1	1	0	FWD
1	0	1	REV
1	1	0->1	FWD
1	0->1	1	REV

Ten's place:

To determine priorities between operation command and JOG.

P4.12	Terminal UP/DOWN rate	0.01Hz/s~65.535Hz/s	1.00Hz/s
-------	-----------------------	---------------------	----------

It is used to adjust the rate of change of frequency when the frequency is adjusted by means of terminal UP/DOWN.

- If P0.22 (Frequency reference resolution) is 2, the setting range is 0.001-65.535 Hz/s.
- If P0.22 (Frequency reference resolution) is 1, the setting range is 0.01-655.35 Hz/s.

P4.13	AI curve 1 minimum input	0.00V~P4.15	0.00V	
P4.14	Corresponding setting of AI curve 1 minimum input	-100.00%~100.0%	0.0%	
P4.15	AI curve 1 maximum input	P4.13~10.00V	10.00V	
P4.16	Corresponding setting of AI curve 1 maximum input	-100.00%~100.0%	100.0%	
P4.17	AI1 filter time	0.00s~10.00s	0.10s	

These parameters are used to define the relationship between the analog input voltage and the corresponding setting. When the analog input voltage exceeds the maximum value (P4.15), the maximum value is used. When the analog input voltage is less than the minimum value (P4.13), the value set in P4.14 (Setting for AI less than minimum input) is used.

When the analog input is current input, 1 mA current corresponds to 0.5 V voltage.

P4.17 (AI1 filter time) is used to set the software filter time of AI1. If the analog input is liable to interference, increase the value of this parameter to stabilize the detected analog input. However, increase of the AI filter time will slow the response of analog detection. Set this parameter properly based on actual conditions.

Graph below are two typical setting examples:

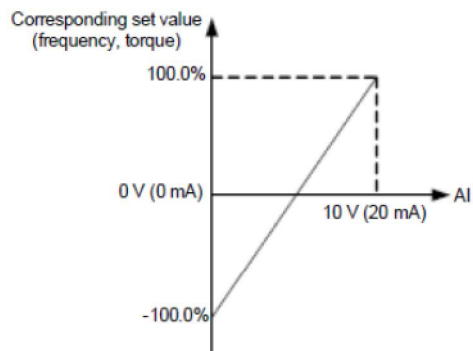
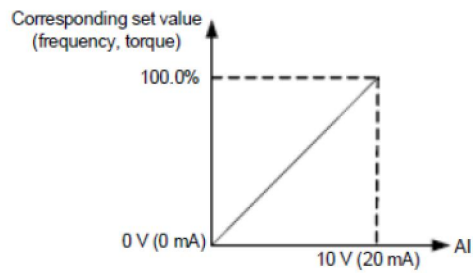

P4.18	AI curve 2 minimum input	0.00V~P4.20	0.00V
P4.19	Corresponding setting of AI curve 2 minimum input	-100.00%~100.0%	0.0%
P4.20	AI curve 2 maximum input	P4.18~10.00V	10.00V
P4.21	Corresponding setting of AI curve 2 maximum input	-100.00%~100.0%	100.0%
P4.22	AI2 filter time	0.00s~10.00s	0.10s
P4.23	AI curve 3 minimum input	-10.00V~P4.25	0.10V
P4.24	Corresponding setting of AI curve 3 minimum input	-100.0%~100.0%	0.0%
P4.25	AI curve 3 maximum input	P4.23~10.00V	4.00V
P4.26	Corresponding setting of AI curve 3 maximum input	-100.0%~100.0%	100.0%
P4.27	AI3 filter time	0.00s~10.00s	0.10s

The method of setting AI2 and AI3 functions is similar to that of setting AI1 function.

P4.28	Pulse minimum input	0.00kHz~P4.30	0.00kHz
P4.29	Corresponding setting of pulse minimum input	-100.0%~100.0%	0.0%
P4.30	Pulse maximum input	P4.28~50.00kHz	50.00
P4.31	Corresponding setting of pulse maximum input	-100.0%~100.0%	100.0%
P4.32	Pulse filter time	0.00s~10.00s	0.10s

These parameters are used to set the relationship between DI5 pulse input and corresponding settings. The pulses can only be input by DI5. The method of setting this function is similar to that of setting AI1 function.

P4.33	AI curve selection	One's place	AI1 curve selection		321
		Curve 1 (2 points, see F4-13 to F4-16)	1		
		Curve 2 (2 points, see F4-13 to F4-16)	2		
		Curve 3 (2 points, see F4-13 to F4-16)	3		
		Ten's place	AI2 curve selection		
		Curve 1 (2 points, see F4-13 to F4-16)	1		
		Curve 2 (2 points, see F4-13 to F4-16)	2		
		Curve 3 (2 points, see F4-13 to F4-16)	3		
		Hundred's place	AI3 curve selection		
		Curve 1 (2 points, see F4-13 to F4-16)	1		
		Curve 2 (2 points, see F4-13 to F4-16)	2		
		Curve 3 (2 points, see F4-13 to F4-16)	3		

The one's place, ten's place and hundred's place of this parameter are respectively used to select the corresponding curve of AI1, AI2 and AI3. Any of the five curves can be selected for AI1, AI2 and AI3.

The DLB1 provides two AI terminals as standard. AI3x is provided by an optional extension card.

P4.34	Setting for AI less than minimum input	One's place	Setting for AI1 less than minimum input		000
		Minimum value		0	
		0.0%		1	
		Ten's place	Setting for AI2 less than minimum input		
		Minimum value		0	
		0.0%		1	
		Hundred's place	Setting for AI3 less than minimum input		
		Minimum value		0	
		0.0%		1	

This parameter is used to determine the corresponding setting when the analog input voltage is less than the minimum value. The unit's digit, ten's digit and hundred's digit of this parameter respectively correspond to the setting for AI1, AI2 and AI3.

If the value of a certain digit is 0, when analog input voltage is less than the minimum input, the corresponding setting of the minimum input (F4-14, F4-19, F4-24) is used.

If the value of a certain digit is 1, when analog input voltage is less than the minimum input, the corresponding value of this analog input is 0.0%.

P4.35	DI1 delay time	0.0s~3600.0s	0.0s
P4.36	DI2 delay time	0.0s~3600.0s	0.0s
P4.37	DI3 delay time	0.0s~3600.0s	0.0s

These parameters are used to set the delay time of the Inverter when the status of DI terminals changes.

Currently, only DI1, DI2 and DI3 support the delay time function.

P4.38	DI valid mode selection 1	One's place	DI1 valid mode		00000
		High level valid		0	
		Low level valid		1	
		Ten's place	DI2 valid mode		

P4.39	DI mode selection2	High level valid	0	00000	
		Low level valid	1		
		Hundred's place	DI3 valid mode		
		High level valid	0		
		Low level valid	1		
		Thousand's place	DI4 valid mode		
		High level valid	0		
		Low level valid	1		
		Ten Thousand's place	DI5 valid mode		
		High level valid	0		
		Low level valid	1		
		One's place	DI6 valid mode		
		High level valid	0		
		Low level valid	1		
		Ten's place	DI7 valid mode		
		High level valid	0		
		Low level valid	1		
		Hundred's place	DI8 valid mode		
High level valid	0				
Low level valid	1				
Thousand's place	DI9 valid mode				
High level valid	0				
Low level valid	1				
Ten Thousand's place	DI10 valid mode				
High level valid	0				
Low level valid	1				

These parameters are used to set the valid mode of DI terminals.

- 0: High level valid

The DI terminal is valid when being connected with COM, and invalid when being disconnected from COM.

- 1: Low level valid

The DI terminal is invalid when being connected with COM, and invalid when being disconnected from COM.

4.7 Output terminals:P5.00-P5.22

The DLB1 provides two analog output (AO) terminals, a digital output (DO) terminal, a relay terminal and a FM terminal (used for high-speed pulse output or open-collector switch signal output) as standard.

If these output terminals cannot satisfy requirements, use an optional I/O extension card that provides a relay terminal (relay 2) and a DO terminal (DO2).

Code	Description	Setting range	Default	Restrictions
P5.00	FM output mode	Pulse output (FMP)	0	0
		Switch signal output (FMR)	1	

The FM terminal is programmable multiplexing terminal. It can be used for high-speed pulse output (FMP), with maximum frequency of 50 kHz. Refer to P5.06 for relevant functions of FMP. It can also be used as open collector switch signal output (FMR).

P5.01	FMR function (open-collector output terminal)	0-44	0	
P5.02	Relay function 1 (T/A-T/B-T/C)	0-44	2	
P5.03	Extension card relay function 2 (P/A-P/B-P/C)	0-44	2	
P5.04	DO1 function selection (open-collector output terminal)	0-44	1	
P5.05	DO2 function selection (open-collector output terminal)	0-44	1	

These five parameters are used to select the functions of the five digital output terminals. T/A-T/B-T/C and P/A-P/B-P/C are respectively the relays on the control board and the extension card.

The functions of the output terminals are described in the following table.

Value	Function	Description
0	No output	The terminal has no function.
1	Inverter running	When the Inverter is running and has output frequency (can be zero), the terminal becomes ON.
2	Fault output (stop)	When the Inverter stops due to a fault, the terminal becomes ON.
3	Frequency-level detection FDT1 output	Refer to the descriptions of P8.19 and P8.20.
4	Frequency reached	Refer to the descriptions of P8.21.

5	Zero-speed running (no output at stop)	If the Inverter runs with the output frequency of 0, the terminal becomes ON. If the Inverter is in the stop state, the terminal becomes OFF.
6	Motor overload pre-warning	The Inverter judges whether the motor load exceeds the overload pre-warning threshold before performing the protection action. If the pre-warning threshold is exceeded, the terminal becomes ON. For motor overload parameters, see the descriptions of P9.00 to P9.02.
7	Inverter overload prewarning	The terminal becomes ON 10s before the Inverter overload protection action is performed.
8	Set count value reached	The terminal becomes ON when the count value reaches the value set in PB.08.
9	Designated count value reached	The terminal becomes ON when the count value reaches the value set in PB.09.
10	Length reached	The terminal becomes ON when the detected actual length exceeds the value set in PB.05.
11	PLC cycle complete	When simple PLC completes one cycle, the terminal outputs a pulse signal with width of 250 ms.
12	Accumulative running time reached	If the accumulative running time of the Inverter exceeds the time set in P8.17, the terminal becomes ON.
13	Frequency limited	If the set frequency exceeds the frequency upper limit or lower limit and the output frequency of the Inverter reaches the upper limit or lower limit, the terminal becomes ON.
14	Torque limited	In speed control mode, if the output torque reaches the torque limit, the Inverter enters the stall protection state and meanwhile the terminal becomes ON.
15	Ready for RUN	If the Inverter main circuit and control circuit become stable, and the Inverter detects no fault and is ready for RUN, the terminal becomes ON.
16	AI1 larger than AI2	When the input of AI1 is larger than the input of AI2, the terminal becomes ON.

17	Frequency upper limit reached	If the running frequency reaches the upper limit, the terminal becomes ON.
18	Frequency lower limit reached (no output at stop)	If the running frequency reaches the lower limit, the terminal becomes ON. In the stop state, the terminal becomes OFF.
19	Undervoltage state output	If the Inverter is in undervoltage state, the terminal becomes ON.
20	Communication	Refer to the communication protocol.
	setting	
21	Reserved	Reserved.
22	Reserved	Reserved.
23	Zero-speed running 2 (having output at stop)	If the output frequency of the Inverter is 0, the terminal becomes ON. In the state of stop, the signal is still ON.
24	Accumulative power- on time reached	If the Inverter accumulative power-on time (P7.13) exceeds the value set in P8.16, the terminal becomes ON.
25	Frequency level detection FDT2 output	Refer to the descriptions of P8.28 and P8.29.
26	Frequency 1 reached	Refer to the descriptions of P8.30 and P8.31.
27	Frequency 2 reached	Refer to the descriptions of P8.32 and P8.33.
28	Current 1 reached	Refer to the descriptions of P8.38 and P8.39.
29	Current 2 reached	Refer to the descriptions of P8.40 and P8.41.
30	Timing reached	If the timing function (P8.42) is valid, the terminal becomes ON after the current running time of the Inverter reaches the set time.
31	A11 input limit exceeded	If A11 input is larger than the value of P8.46 (A11 input voltage upper limit) or lower than the value of P8.45 (A11 input voltage lower limit), the terminal becomes ON.
32	Load becoming 0	If the load becomes 0, the terminal becomes ON.
33	Reverse running	If the Inverter is in the reverse running state, the terminal becomes ON.
34	Zero current state	Refer to the descriptions of P8.28 and P8.29.

35	Module temperature reached	If the heatsink temperature of the inverter module (P7.07) reaches the set module temperature threshold (P8.47), the terminal becomes ON.
36	Software current limit exceeded	Refer to the descriptions of P8.36 and P8.37.
37	Frequency lower limit reached (having output at stop)	If the running frequency reaches the lower limit, the terminal becomes ON. In the stop state, the signal is still ON.
38	Alarm output	If a fault occurs on the Inverter and the Inverter continues to run, the terminal outputs the alarm signal.
39	Motor overheat warning	If the motor temperature reaches the temperature set in P9.58 (Motor overheat warning threshold), the terminal becomes ON. You can view the motor temperature by using d0.34.
40	Current running time reached	If the current running time of Inverter exceeds the value of P8.53, the terminal becomes ON.
42	Command status	Direct output
43	FWD command status	
44	REV command status	

P5.06	FMP output selection	0-16	0	
P5.07	AO1 output selection	0-16	0	
P5.08	AO2 output selection	0-16	1	

The output pulse frequency of the FMP terminal ranges from 0.01 kHz to "Maximum FMP output frequency" (P5.09). The value of P5.09 is between 0.01 kHz and 100.00 kHz.

The output range of AO1 and AO2 is 0-10 V or 0-20 mA. The relationship between pulse and analog output ranges and corresponding functions is listed in the following table.

Value	Function	Description
0	Running frequency	0 to maximum output frequency
1	Set frequency	0 to maximum output frequency
2	Output current	0 to 2 times of rated motor current
3	Output torque (absolute value)	0 to 2 times of rated motor torque
4	Output power	0 to 2 times of rated power

5	Output voltage	0 to 1.2 times of rated Inverter voltage
6	Pulse input	0.01-100.00 kHz
7	AI1	0-10 V
8	AI2	0-10 V (or 0-20 mA)
9	AI3	0-0 V
10	Length	0 to maximum set length
11	Count value	0 to maximum count value
12	Communication setting	0.0%-100.0%
13	Motor rotational speed	0 to rotational speed corresponding to maximum output frequency
14	Output current	0.0-1000.0 A
15	Output voltage	0.0-000.0 V
16	Output torque (actual value)	-2 times of rated motor torque to 2 times of rated motor torque

P5.09	Maximum FMP output frequency	0.01kHz~100.00kHz	50.00kHz
-------	------------------------------	-------------------	----------

If the FM terminal is used for pulse output, this parameter is used to set the maximum frequency of pulse output.

P5.10	AO1 zero offset coefficient	-100.0%~+100.0%	0.0%
P5.11	AO1 gain	-10.00~+10.00	1.00
P5.12	AO2 zero offset coefficient	-100.0%~+100.0%	0.00%
P5.13	AO2 gain	-10.00~+10.00	1.00

These parameters are used to correct the zero drift of analog output and the output amplitude deviation. They can also be used to define the desired AO curve.

If "b" represents zero offset, "k" represents gain, "Y" represents actual output, and "X" represents standard output, the actual output is: $Y = kX + b$.

The zero offset coefficient 100% of AO1 and AO2 corresponds to 10 V (or 20 mA). The standard output refers to the value corresponding to the analog output of 0 to 10 V (or 0 to 20 mA) with no zero offset or gain adjustment.

For example, if the analog output is used as the running frequency, and it is expected that the output is 8 V when the frequency is 0 and 3 V at the maximum frequency, the gain shall be set to -0.50, and the zero offset shall be set to 80%.

P5.17	FMR output delay time	0.0s~3600.0s	0.0s	
P5.18	Relay 1 output delay time	0.0s~3600.0s	0.0s	
P5.19	Relay 2 output delay time	0.0s~3600.0s	0.0s	
P5.20	DO1 output delay time	0.0s~3600.0s	0.0s	
P5.21	DO2 output delay time	0.0s~3600.0s	0.0s	

These parameters are used to set the delay time of output terminals FMR, relay 1, relay 2, DO1 and DO2 from status change to actual output.

P5.22	DO valid mode selection	One's place	FMR valid mode	00000	
		Positive logic			0
		Negative logic			1
		Ten's place	RELAY1 valid mode		
		Positive logic			0
		Negative logic			1
		Hundred's place	RELAY2 valid mode		
		Positive logic			0
		Negative logic			1
		Thousand's place	DO1 valid mode		
		Positive logic			0
		Negative logic			1
		Ten thousand's place	DO2 valid mode		
		Positive logic			0
		Negative logic			1

It is used to set the logic of output terminals FMR, relay 1, relay 2, DO1 and DO2.

- 0: Positive logic

The output terminal is valid when being connected with COM, and invalid when being disconnected from COM.

- 1: Positive logic

The output terminal is invalid when being connected with COM, and valid when being disconnected from COM.

4.8 Start/stop control:P6.00-P6.15

Code	Description	Setting range	Def ault	Restri ctions
P6.00	Start mode	Direct start	0	0
		Rotational speed tracking restart	1	
		Pre-excited start (asynchronous motor)	2	

- 0: Direct start

-If the DC braking time is set to 0, the Inverter starts to run at the startup frequency.

-If the DC braking time is not 0, the Inverter performs DC braking first and then starts to run at the startup frequency. It is applicable to small-inertia load application where the motor is likely to rotate at startup.

- 1: Rotational speed tracking restart

The Inverter judges the rotational speed and direction of the motor first and then starts at the tracked frequency. Such smooth start has no impact on the rotating motor. It is applicable to the restart upon instantaneous power failure of large-inertia load. To ensure the performance of rotational speed tracking restart, set the motor parameters in group F1 correctly.

- 2: Pre-excited start (asynchronous motor)

It is valid only for asynchronous motor and used for building the magnetic field before the motor runs. For pre-excited current and pre-excited time, see parameters of F6-05 and F6-06.

-If the pre-excited time is 0, the Inverter cancels pre-excitation and starts to run at startup frequency.

- If the pre-excited time is not 0, the Inverter pre-excites first before startup, improving the dynamic response of the motor.

P6.01	Speed track mode	From frequency at stop	0	0
		From zero speed	1	
		From maximum frequency	2	

To complete the rotational speed tracking process within the shortest time, select the proper mode in which the Inverter tracks the motor rotational speed.

- 0: From frequency at stop

It is the commonly selected mode.

- 1: From zero frequency

It is applicable to restart after a long time of power failure.

- 2: From the maximum frequency

It is applicable to the power-generating load.

P6.02	Rotational speed tracking speed	1~100	20	
-------	---------------------------------	-------	----	--

In the rotational speed tracking restart mode, select the rotational speed tracking speed. The larger the value is, the faster the tracking is. However, too large value may cause unreliable tracking.

P6.03	Startup frequency	0.00Hz~10.00Hz	0.00Hz	
P6.04	Startup frequency holding time	0.0s~100.0s	0.0s	

To ensure the motor torque at Inverter startup, set a proper startup frequency. In addition, to build excitation when the motor starts up, the startup frequency must be held for a certain period.

The startup frequency (P6.03) is not restricted by the frequency lower limit. If the set target frequency is lower than the startup frequency, the Inverter will not start and stays in the standby state.

During switchover between forward rotation and reverse rotation, the startup frequency holding time is disabled. The holding time is not included in the acceleration time but in the running time of simple PLC.

Example 1:

P0.03 = 0 The frequency source is digital setting.
P0.08 = 2.00 Hz The digital setting frequency is 2.00 Hz.
P6.03 = 5.00 Hz The startup frequency is 5.00 Hz.
P6.04 = 2.0s The startup frequency holding time is 2.0s.

In this example, the Inverter stays in the standby state and the output frequency is 0.00 Hz.

Example 2:

P0.03 = 0 The frequency source is digital setting.
P0.08 = 10.00 Hz The digital setting frequency is 10.00 Hz.
P6.03 = 5.00 Hz The startup frequency is 5.00 Hz.
P6.04 = 2.0s The startup frequency holding time is 2.0s.

In this example, the Inverter accelerates to 5.00 Hz, and then accelerates to the set frequency 10.00 Hz after 2s.

P6.05	Startup DC braking current/Pre-excited current	0%~100%	0%	
P6.06	Startup DC braking time/Pre-excited time	0.0s~100.0s	0.0s	

Startup DC braking is generally used during restart of the Inverter after the rotating motor stops. Pre-excitation is used to make the Inverter build magnetic field for the asynchronous motor before startup to improve the responsiveness.

Startup DC braking is valid only for direct start (P6.00 = 0). In this case, the Inverter performs DC braking at the set startup DC braking current. After the startup DC braking time, the Inverter starts to run. If the startup DC braking time is 0, the Inverter starts directly without DC braking. The larger the startup DC braking current is, the larger the braking force is.

If the startup mode is pre-excited start (P6.00 = 3), the Inverter builds magnetic field based on the set pre-excited current. After the pre-excited time, the Inverter starts to run. If the pre-excited time is 0, the Inverter starts directly without pre-excitation.

The startup DC braking current or pre-excited current is a percentage relative to the base value.

- If the rated motor current is less than or equal to 80% of the rated Inverter current, the base value is the rated motor current.
- If the rated motor current is greater than 80% of the rated Inverter current, the base value is 80% of the rated Inverter current.

P6.07	Acceleration/ Deceleration mode	Linear acceleration/deceleration	0	0
		S-curve acceleration/deceleration A	1	
		S-curve acceleration/deceleration B	2	

It is used to set the frequency change mode during the Inverter start and stop process. • 0: Linear acceleration/deceleration.

The output frequency increases or decreases in linear mode. The DLB1 provides four group of acceleration/deceleration time, which can be selected by using P4.00 to P4.08.

- 1: S-curve acceleration/deceleration A

The output frequency increases or decreases along the S curve. This mode is generally used in the applications where start and stop processes are relatively smooth, such as elevator and conveyor belt. P6.08 and P6.09 respectively define the time proportions of the start segment and the end segment.

- 2: S-curve acceleration/deceleration B

In this curve, the rated motor frequency f is always the inflexion point. This mode is usually used in applications where acceleration/deceleration is required at the speed higher than the rated frequency.

When the set frequency is higher than the rated frequency, the acceleration/ deceleration time is:

$$t = \left(\frac{4}{9} \times \frac{f}{f_b} + \frac{5}{9} \right) \times T$$

In the formula, f is set frequency; f_b is motor rated frequency; T is the acceleration time from 0 Hz to f_b .

P6.08	Time proportion of S-curve start segment	0.0%~(100.0%-P6.09)	30.0%
P6.09	Time proportion of S-curve end segment	0.0%~(100.0%-P6.08)	30.0%

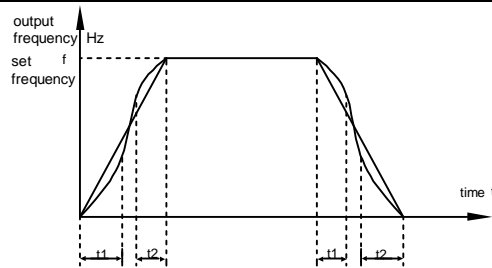

Graph4-11 S-curve acceleration/deceleration A

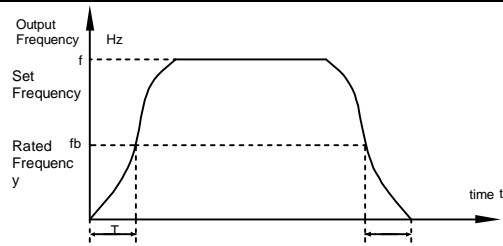

Graph4.12 S-curve acceleration/deceleration B

P6.10	Stop mode	Decelerate to stop	0	0
		Coast to stop	1	

0: Decelerate to stop

After the stop command is enabled, the Inverter decreases the output frequency according to the deceleration time and stops when the frequency decreases to zero.

1: Coast to stop

After the stop command is enabled, the Inverter immediately stops the output. The motor will coast to stop based on the mechanical inertia.

P6.11	Initial frequency of stop DC braking	0.00Hz~ maximum frequency	0.00Hz
P6.12	Waiting time of stop DC braking	0.0s~36.0s	0.0s
P6.13	Stop DC braking current	0%~100%	0%
P6.14	Stop DC braking time	0.0s~100.0s	0.0s

P6.11 (Initial frequency of stop DC braking)

During the process of decelerating to stop, the Inverter starts DC braking when the running frequency is lower than the value set in P6.11.

- P6.12 (Waiting time of stop DC braking)

When the running frequency decreases to the initial frequency of stop DC braking, the Inverter stops output for a certain period and then starts DC braking. This prevents faults such as overcurrent caused due to DC braking at high speed.

- P6.13 (Stop DC braking current)

This parameter specifies the output current at DC braking and is a percentage relative to the base value.

- If the rated motor current is less than or equal to 80% of the rated Inverter current, the base value is the rated motor current.

- If the rated motor current is greater than 80% of the rated Inverter current, the base value is 80% of the rated Inverter current.

- P6.14 (Stop DC braking time)

This parameter specifies the holding time of DC braking. If it is set to 0, DC braking is cancelled. The stop DC braking process is shown in the following figure.

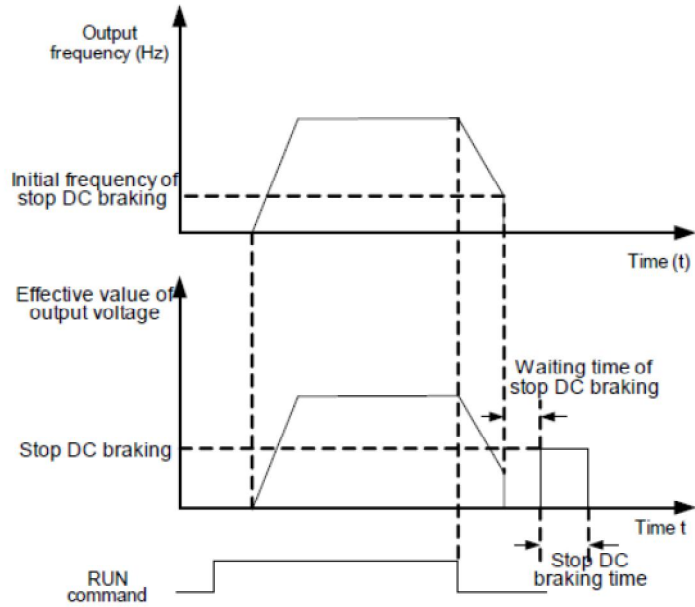

P6.15	Brake use ratio	0%~100%	100%
-------	-----------------	---------	------

It is valid only for the Inverter with internal braking unit and used to adjust the duty ratio of the braking unit. The larger the value of this parameter is, the better the braking result will be. However, too larger value causes great fluctuation of the Inverter bus voltage during the braking process.

4.9 Operation panel and display:P7.00-P7.14

Code	Description	Setting range	Def ault	Restri ctions
P7.01	DIR/JOG function	DIR/JOG disabled	0	0
		Switchover between operation panel control and remote command control (terminal or communication)	1	
		Switchover between forward rotation and reverse rotation	2	
		Forward JOG	3	
		Reverse JOG	4	

DIR/JOG key is a multifunctional key. You can set the function of the DIR/JOG key by using this parameter. You can perform switchover by using this key both in stop or running state.

- 0: DIR/JOG key disabled This key is disabled.
- 1: Switchover between operation panel control and remote command control (terminal or communication)
You can perform switchover from the current command source to the operation panel control (local operation). If the current command source is operation panel control, this key is invalid.
- 2: Switchover between forward rotation and reverse rotation
You can change the direction of the frequency reference by using the DIR/JOG key. It is valid only when the current command source is operation panel control.
- 3: Forward JOG
You can perform forward JOG (FJOG) by using the DIR/JOG key.
- 4: Reverse JOG
You can perform reverse JOG (FJOG) by using the DIR/JOG key.

P7.02	STOP/RESET	STOP/RESET key enabled only in operation panel control	0	1
		STOP/RESET key enabled in any operation mode	1	
P7.03	LED display running parameters 1	0000~FFFF	1F	

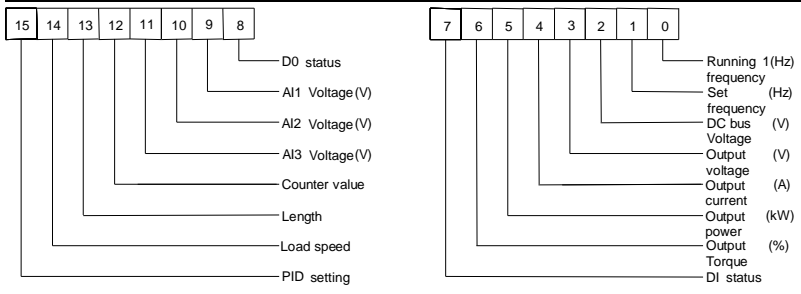

If a parameter needs to be displayed during the running, set the corresponding bit to 1, and set P7.03 to the hexadecimal equivalent of this binary number.

P7.04	LED display running parameters 2	0000~FFFF	0
-------	----------------------------------	-----------	---

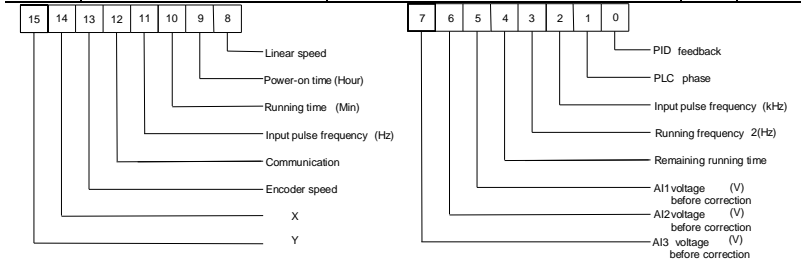

If a parameter needs to be displayed during the running, set the corresponding bit to 1, and set P7.04 to the hexadecimal equivalent of this binary number.

These two parameters are used to set the parameters that can be viewed when the Inverter is in the running state. You can view a maximum of 32 running state parameters that are displayed from the lowest bit of P7.03.

P7.05	LEDdisplay stopparameters	0000~FFFF	33
-------	---------------------------	-----------	----

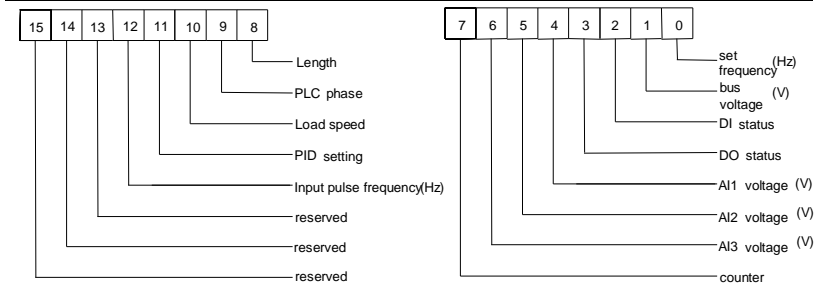

If a parameter needs to be displayed during the running, set the corresponding bit to 1, and set P7.05 to the hexadecimal equivalent of this binary number.

P7.06	Load speed display coefficient	0.0001~6.5000	1.000 0	
-------	--------------------------------	---------------	------------	--

This parameter is used to adjust the relationship between the output frequency of the Inverter and the load speed. For details, see the description of P7.12.

P7.07	Heatsink temperature of inverter module	0.0 ~100.0	12	
-------	---	------------	----	--

It is used to display the insulated gate bipolar transistor (IGBT) temperature of the inverter module, and the IGBT overheat protection value of the inverter module depends on the model.

P7.08	Rectification module temperature	0.0 ~100.0	0	
-------	----------------------------------	------------	---	--

P7.09	Accumulative running time	0h~65535h	0h	
-------	---------------------------	-----------	----	--

It is used to display the accumulative running time of the Inverter. After the accumulative running time reaches the value set in P8.17, the terminal with the digital output function 12 becomes ON.

P7.10	Product number	Inverter Product number	-	
-------	----------------	-------------------------	---	--

P7.11	Software version	Software version of control board	-	
-------	------------------	-----------------------------------	---	--

P7.12	Number of decimal places for load speed display	0decimal place	0	1
		1decimal place	1	
		2decimal place	2	
		3decimal place	3	

P7.12 is used to set the number of decimal places for load speed display. The following gives an example to explain how to calculate the load speed:

Assume that P7.06 (Load speed display coefficient) is 2.000 and P7.12 is 2 (2 decimal places). When the running frequency of the Inverter is 40.00 Hz, the load speed is $40.00 \times 2.000 = 80.00$ (display of 2 decimal places).

If the Inverter is in the stop state, the load speed is the speed corresponding to the set frequency, namely, "set load speed". If the set frequency is 50.00 Hz, the load speed in the stop state is $50.00 \times 2.000 = 100.00$ (display of 2 decimal places).

P7.13	Accumulative power-on time	0h~65535h	-	
-------	----------------------------	-----------	---	--

It is used to display the accumulative power-on time of the Inverter since the delivery. If the time reaches the set power-on time (P8.17), the terminal with the digital output function 24 becomes ON.

P7.14	Accumulative power consumption	0~65535 kWh	-	
-------	--------------------------------	-------------	---	--

It is used to display the accumulative power consumption of the Inverter until now.

4.10 Auxiliary functions:P8.00-P8.53

Code	Description	Setting range	Default	Restrictions
P8.00	JOG running frequency	0.00Hz- maximum frequency	2.00Hz	
P8.01	JOG acceleration time	0.0s~6500.0s	20.0s	
P8.02	JOG deceleration time	0.0s~6500.0s	20.0s	

These parameters are used to define the set frequency and acceleration/deceleration time of the Inverter when jogging. The startup mode is "Direct start" (P6.00 = 0) and the stop mode is "Decelerate to stop" (P6.10 = 0) during jogging.

P8.03	Acceleration time 2	0.0s~6500.0s	10.0s	
P8.04	Deceleration time 2	0.0s~6500.0s	10.0s	
P8.05	Acceleration time 3	0.0s~6500.0s	10.0s	
P8.06	Deceleration time 3	0.0s~6500.0s	10.0s	
P8.07	Acceleration time 4	0.0s~6500.0s	10.0s	
P8.08	Deceleration time 4	0.0s~6500.0s	10.0s	

The DLB1 provides a total of four groups of acceleration/deceleration time, that is, the preceding three groups and the group defined by P0.17 and P0.18.

Definitions of four groups are completely the same. You can switch over between the four groups of acceleration/deceleration time through different state combinations of DI terminals. For more details, see the descriptions of P4.01 to P4.05.

P8.09	Jump frequency 1	0.00Hz- maximum frequency	0.00Hz	
P8.10	Jump frequency 2	0.00Hz- maximum frequency	0.00Hz	
P8.11	Frequency jump amplitude	0.00Hz- maximum frequency	0.00Hz	

If the set frequency is within the frequency jump range, the actual running frequency is the jump frequency close to the set frequency. Setting the jump frequency helps to avoid the mechanical resonance point of the load.

The DLB1 supports two jump frequencies. If both are set to 0, the frequency jump function is disabled. The principle of the jump frequencies and jump amplitude is shown in the following figure.

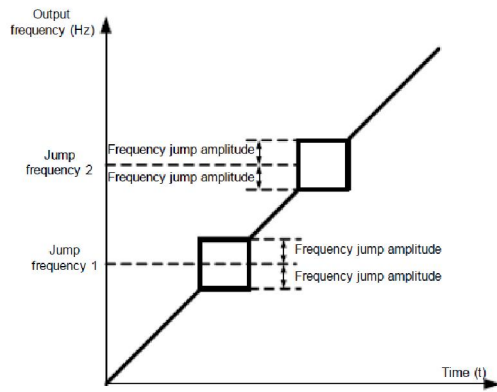

P8.12	Forward/Reverse rotation dead-zone time	0.00s~3000.0s	0.0s
-------	---	---------------	------

It is used to set the time when the output is 0 Hz at transition of the Inverter forward rotation and reverse rotation, as shown in the following figure.

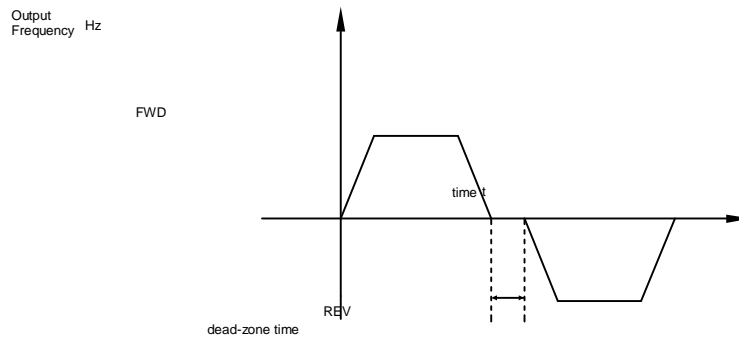

P8.13	Reverse control	Enabled	0	0
		Disabled	1	

It is used to set whether the Inverter allows reverse rotation. In the applications where reverse rotation is prohibited, set this parameter to 1.

P8.14	Running mode when set frequency lower than frequency lower limit	Run at frequency lower limit	0	0
		Stop (needs startcommand)	1	
		Run at zero speed	2	
		Stop (restart automatically if frequency is higher than lower limit)	3	

It is used to set the Inverter running mode when the set frequency is lower than the frequency lower limit. The DLB1 provides three running modes to satisfy requirements of various applications.

P8.15	Droop control	0.00Hz~10.00Hz	0.00Hz	
-------	---------------	----------------	--------	--

This function is used for balancing the workload allocation when multiple motors are used to drive the same load.

The output frequency of the Inverters decreases as the load increases. You can reduce the workload of the motor under load by decreasing the output frequency for this motor, implementing workload balancing between multiple motors.

P8.16	Accumulative power-on time threshold	0h~65000h	0h	
-------	--------------------------------------	-----------	----	--

If the accumulative power-on time (P7.13) reaches the value set in this parameter, the corresponding DO terminal becomes ON.

For example, combining DI/DO functions, to implement the function that the Inverter reports an alarm when the actual accumulative power-on time reaches the threshold of 100 hours, perform the setting as follows:

- 1) Set DI1 to user-defined fault 1: P4.00 = 44.
- 3) Set DO1 to power-on time reached: P5.04 = 24.
- 4) Set the accumulative power-on time threshold to 100 h: P8.16 = 100h.

Then, the Inverter reports 26=E.ArA when the accumulative power-on time reaches 100 hours.

P8.17	Accumulative running time threshold	0h~65000h	0h	
-------	-------------------------------------	-----------	----	--

It is used to set the accumulative running time threshold of the Inverter. If the accumulative running time (P7.09) reaches the value set in this parameter, the corresponding DO terminal becomes ON.

P8.18	Startup protection	No	0	0
		Yes	1	

This parameter is used to set whether to enable the safety protection. If it is set to 1, the Inverter does not respond to the run command valid upon Inverter power-on (for example, an input terminal is ON before power-on). The Inverter responds only after the run command is cancelled and becomes valid again.

In addition, the Inverter does not respond to the run command valid upon fault reset of the Inverter. The run protection can be disabled only after the run command is cancelled.

In this way, the motor can be protected from responding to run commands upon power-on or fault reset in unexpected conditions.

P8.19	Frequency detection value (FDT1)	0.00Hz~ maximum frequency	50.00Hz	
P8.20	Frequency detection hysteresis (FDT hysteresis 1)	0.0%~100.0%(FDT1 电平)	5.0%	

If the running frequency is higher than the value of P8.19, the corresponding DO terminal becomes ON. If the running frequency is lower than value of P8.19, the DO terminal goes OFF

These two parameters are respectively used to set the detection value of output frequency and hysteresis value upon cancellation of the output. The value of P8.20 is a percentage of the hysteresis frequency to the frequency detection value (P8.19).

The FDT function is shown in the following figure.

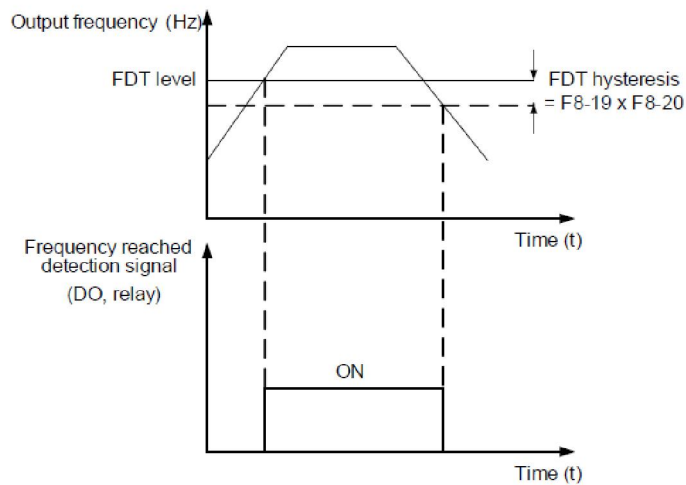

P8.21	Detection range of frequency reached	0.00%~100%(maximum frequency)	0.0%	
-------	--------------------------------------	--------------------------------	------	--

If the Inverter running frequency is within the certain range of the set frequency, the corresponding DO terminal becomes ON.

This parameter is used to set the range within which the output frequency is detected to reach the set frequency. The value of this parameter is a percentage relative to the maximum frequency. The detection range of frequency reached is shown in the following figure.

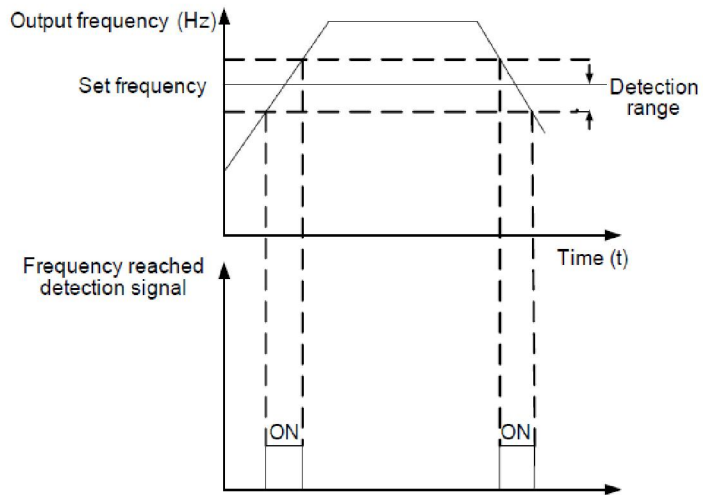

P8.22	Jump frequency during acceleration/deceleration	Disabled	0	0
		Enabled	1	

It is used to set whether the jump frequencies are valid during acceleration/deceleration.

When the jump frequencies are valid during acceleration/deceleration, and the running frequency is within the frequency jump range, the actual running frequency will jump over the set frequency jump amplitude (rise directly from the lowest jump frequency to the highest jump frequency).

The following figure shows the diagram when the jump frequencies are valid during acceleration/deceleration.

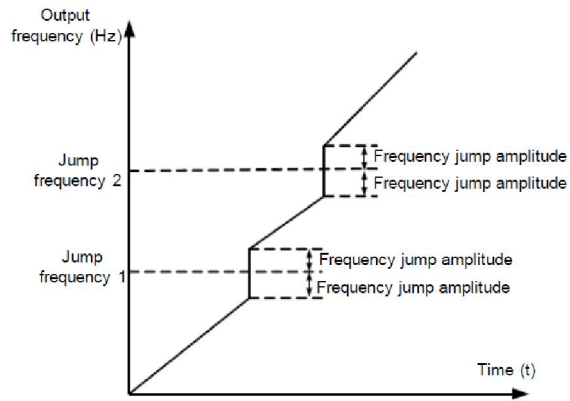

P8.25	Frequency switchover point between acceleration time 1 and acceleration time 2	0.00Hz~ maximum frequency	0.00Hz
P8.26	Frequency switchover point between deceleration time 1 and deceleration time 2	0.00Hz~ maximum frequency	0.00Hz

This function is valid when motor 1 is selected and acceleration/deceleration time switchover is not performed by means of DI terminal. It is used to select different groups of acceleration/ deceleration time based on the running frequency range rather than DI terminal during the running process of the Inverter.

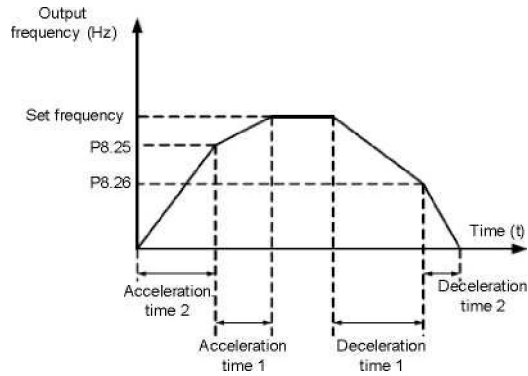

During acceleration, if the running frequency is smaller than the value of P8.25, acceleration time 2 is selected. If the running frequency is larger than the value of P8.25, acceleration time 1 is selected.

During deceleration, if the running frequency is larger than the value of P8.26, deceleration time 1 is selected. If the running frequency is smaller than the value of P8.26, deceleration time 2 is selected.

P8.27	Terminal JOG preferred	Disabled	0	0
		Enabled	1	

It is used to set whether terminal JOG is preferred.

If terminal JOG is preferred, the Inverter switches to terminal JOG running state when there is a terminal JOG command during the running process of the Inverter.

P8.28	Frequency detection value (FDT2)	0.00Hz- maximum frequency	50.00Hz
P8.29	Frequency detection hysteresis (FDT hysteresis 2)	0.0%~100.0%(FDT2 Level)	5.0%

The frequency detection function is the same as FDT1 function. For details, refer to the descriptions of P8.19 and P8.20.

P8.30	Any frequency reaching detection value 1	0.00Hz- maximum frequency	50.00Hz
P8.31	Any frequency reaching detection amplitude 1	0.0%~100.0%(maximum frequency)	0.0%
P8.32	Any frequency reaching detection value 2	0.00Hz- maximum frequency	50.00Hz
P8.33	Any frequency reaching detection amplitude 2	0.0%~100.0%(maximum frequency)	0.0%

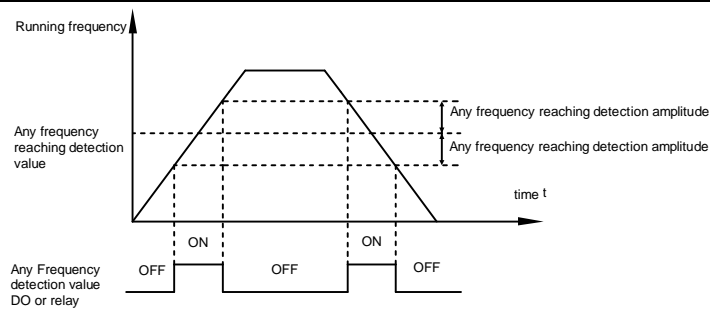

If the output frequency of the Inverter is within the positive and negative amplitudes of the any frequency reaching detection value, the corresponding DO becomes ON.

The DLB1 provides two groups of any frequency reaching detection parameters, including frequency detection value and detection amplitude, as shown in the graph above.

P8.34	Zero current detection level	0.0%~300.0%(motorrated current)	5.0%
P8.35	Zero current detection delay time	0.00s~600.00s	0.10s

If the output current of the Inverter is equal to or less than the zero current detection level and the duration exceeds the zero current detection delay time, the corresponding DO becomes ON. The zero current detection is shown in the following figure.

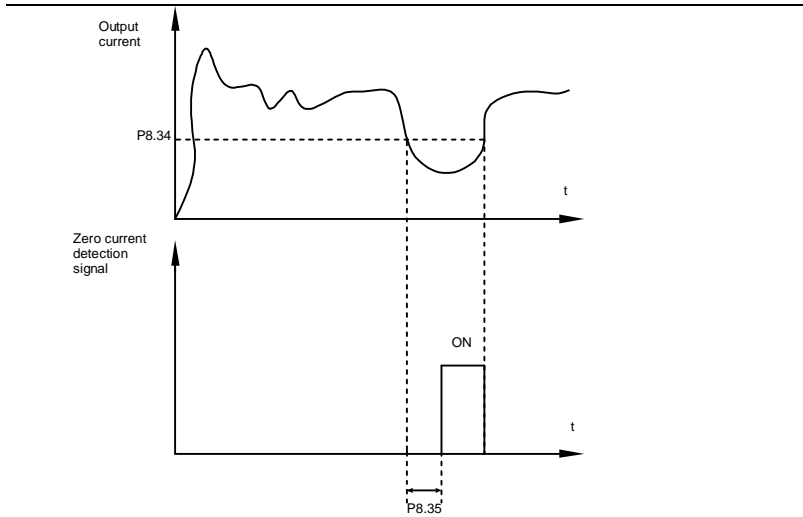

P8.36	Output over-current threshold	0.0%(No detection) 0.1%~300.0%(motorrated current)	200.0%	
P8.37	Output over-current detection delay time	0.00s~600.00s	0.00s	

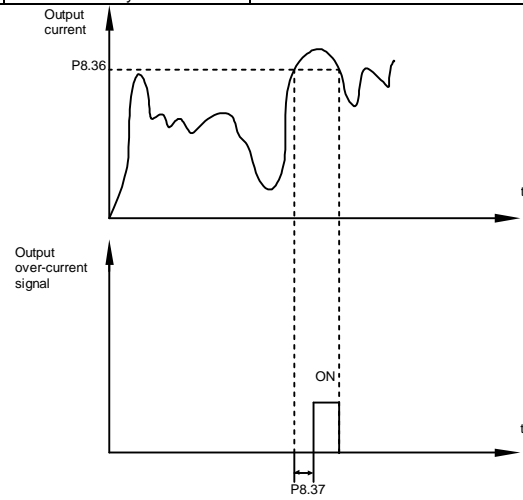

If the output current of the Inverter is equal to or higher than the overcurrent threshold and the duration exceeds the detection delay time, the corresponding DO becomes ON. The output overcurrent detection function is shown in the graph above.

P8.38	Any current reaching 1	0.0%~300.0%(motorrated current)	100.0%
P8.39	Any current reaching amplitude 1	0.0%~300.0%(motorrated current)	0.0%
P8.40	Any current reaching 2	0.0%~300.0%(motorrated current)	100.0%
P8.41	Any current reaching amplitude 2	0.0%~300.0%(motorrated current)	0.0%

If the output current of the Inverter is within the positive and negative amplitudes of any current reaching detection value, the corresponding DO becomes ON.

The DLB1 provides two groups of any current reaching detection parameters, including current detection value and detection amplitudes, as shown in the following figure

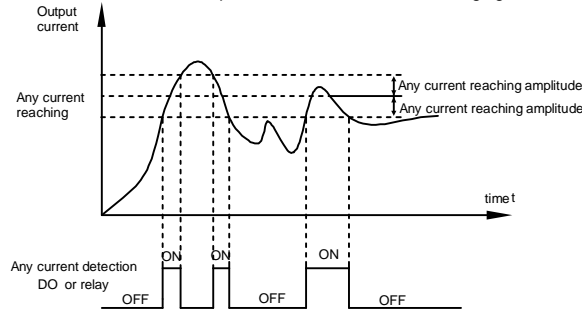

P8.42	Timing function	Disabled	0	0
		Enabled	1	
P8.43	Timing duration source	P8.44 setting	0	0
		AI1	1	
		AI2	2	
		AI3(keyboard potentiometer)	3	
P8.44	Timing duration	0.0Min~6500.0Min	0.0Min	

If P8.42 is set to 1, the Inverter starts to time at startup. When the set timing duration is reached, the Inverter stops automatically and meanwhile the corresponding DO becomes ON.

The Inverter starts timing from 0 each time it starts up and the remaining timing duration can be queried by d0.20.

The timing duration is set in P8.43 and P8.44, in unit of minute.

P8.45	AI1 input voltage lower limit	0.00V~P8.46	3.10V
P8.46	AI1 input voltage upper limit	P8.45~10.00V	6.80V

These two parameters are used to set the limits of the input voltage to provide protection on the Inverter. When the AI1 input is larger than the value of P8.46 or smaller than the value of P8.45, the corresponding DO becomes ON, indicating that AI1 input exceeds the limit.

P8.47	Module temperature threshold	0.00 ~100	75	
-------	------------------------------	-----------	----	--

When the heatsink temperature of the Inverter reaches the value of this parameter, the corresponding DO becomes ON, indicating that the module temperature reaches the threshold.

P8.48	Cooling fan control	Fan working during running	0	0
		Fan working continuously	1	

It is used to set the working mode of the cooling fan. If this parameter is set to 0, the fan works when the Inverter is in running state. When the Inverter stops, the cooling fan works if the heatsink temperature is higher than 40°C, and stops working if the heatsink temperature is lower than 40°C.

If this parameter is set to 1, the cooling fan keeps working after power-on.

P8.49	Wakeup frequency	Dormant frequency(P8.51)~ maximum frequency(P0.10)	0.00Hz	
P8.50	Wakeup delay time	0.0s~6500.0s	0.0s	
P8.51	Dormant frequency	0.00Hz~wakeup frequency(P8.49)	0.00Hz	
P8.52	Dormant delay time	0.0s~6500.0s	0.0s	

These parameters are used to implement the dormant and wakeup functions in the water supply application.

When the Inverter is in running state, the Inverter enters the dormant state and stops automatically after the dormant delay time (P8.52) if the set frequency is lower than or equal to the dormant frequency (P8.51).

When the Inverter is in dormant state and the current running command is effective, the Inverters starts up after the wakeup delay time (P8.50) if the set frequency is higher than or equal to the wakeup frequency (P8.49).

Generally, set the wakeup frequency equal to or higher than the dormant frequency. If the wakeup frequency and dormant frequency are set to 0, the dormant and wakeup functions are disabled.

When the dormant function is enabled, if the frequency source is PID, whether PID operation is performed in the dormant state is determined by PA.28. In this case, select PID operation enabled in the stop state (FA-28 = 1).

P8.53	Current running time reached	0.0Min~6500.0Min	0.0Min	
-------	------------------------------	------------------	--------	--

When the output power (d0.05) is not equal to the required value, you can perform linear correction on output power by using this parameter.

4.11 Fault and protection:P9.00-P9.70

Code	Description	Setting range	Default	Restri ctions
P9.00	Motor overload protection selection	Disabled	0	1
		Enabled	1	
P9.01	Motor overload protection gain	0.20~10.00	1.00	

- P9.00 = 0

The motor overload protective function is disabled. The motor is exposed to potential damage due to overheating. A thermal relay is suggested to be installed between the Inverter and the motor.

- P9.00 = 1

The Inverter judges whether the motor is overloaded according to the inverse time-lag curve of the motor overload protection.

The inverse time-lag curve of the motor overload protection is:

220% x P9.01 x rated motor current (if the load remains at this value for one minute, the Inverter reports motor overload fault), or

150% x P9.01 x rated motor current (if the load remains at this value for 60 minutes, the Inverter reports motor overload fault)

Set P9.01 properly based on the actual overload capacity. If the value of P9.01 is set too large, damage to the motor may result because the motor overheats but the Inverter does not report the alarm.

P9.02	Motor overload warning coefficient	50%~100%	80 %	
-------	------------------------------------	----------	------	--

This function is used to give a warning signal to the control system via DO before motor overload protection. This parameter is used to determine the percentage, at which pre-warning is performed before motor overload. The larger the value is, the less advanced the pre-warning will be.

When the accumulative output current of the Inverter is greater than the value of the overload inverse time-lag curve multiplied by P9.02, the DO terminal on the Inverter allocated with function 6 (Motor overload pre-warning) becomes ON.

P9.03	Over-voltage stall gain	0(No stall over-voltage)~100	0	
P9.04	Over-voltage stall protective voltage	120%~150%(three phase)	130%	

When the DC bus voltage exceeds the value of P9.04 (Overvoltage stall protective voltage) during deceleration of the Inverter, the Inverter stops deceleration and keeps the present running frequency. After the bus voltage declines, the Inverter continues to decelerate.

P9.03 (Overvoltage stall gain) is used to adjust the overvoltage suppression capacity of the Inverter. The larger the value is, the greater the overvoltage suppression capacity will be.

In the prerequisite of no overvoltage occurrence, set P9.03 to a small value.

For small-inertia load, the value should be small. Otherwise, the system dynamic response will be slow. For large-inertia load, the value should be large. Otherwise, the suppression result will be poor and an overvoltage fault may occur.

If the overvoltage stall gain is set to 0, the overvoltage stall function is disabled.

P9.05	Over-current stall gain	0~100	20	
P9.06	Over-current stall protective current	100%~200%	150%	

When the output current exceeds the overcurrent stall protective current during acceleration/ deceleration of the Inverter, the Inverter stops acceleration/deceleration and keeps the present running frequency. After the output current declines, the Inverter continues to accelerate/decelerate.

P9.05 (Overcurrent stall gain) is used to adjust the overcurrent suppression capacity of the Inverter. The larger the value is, the greater the overcurrent suppression capacity will be. In the prerequisite of no overcurrent occurrence, set tP9.05 to a small value.

For small-inertia load, the value should be small. Otherwise, the system dynamic response will be slow. For large-inertia load, the value should be large. Otherwise, the suppression result will be poor and overcurrent fault may occur.

If the overcurrent stall gain is set to 0, the overcurrent stall function is disabled.

P9.07	Short-circuit to ground upon power- on	Disabled	0	1
		Enabled	1	

It is used to determine whether to check the motor is short-circuited to ground at power-on of the Inverter. If this function is enabled, the Inverter's UVW will have voltage output a while after power-on.

P9.09	Fault auto reset times	0~20	0	
-------	------------------------	------	---	--

It is used to set the times of fault auto resets if this function is used. After the value is exceeded, the Inverter will remain in the fault state.

P9.10	DO action during fault auto reset	No action	0	0
		Action	1	

It is used to decide whether the DO acts during the fault auto reset if the fault auto reset function is selected.

P9.11	Time interval of fault auto reset	0.1s~100.0s	1.0s	
-------	-----------------------------------	-------------	------	--

It is used to set the waiting time from the alarm of the Inverter to fault auto reset.

P9.12	Input phase loss protection	One's place	Input phase loss protection	11	
		Disabled		0	
		Enabled		1	
		Ten's place	Contacting energizing protection		
		Disabled		0	
		Enabled		1	

It is used to determine whether to perform input phase loss or contactor energizing protection. (Only available for DLB1 series inverter over 18.5KW models)

P9.13	Output phase loss protection selection	Disabled	0	1
		Enabled	1	

It is used to determine whether to perform output phase loss protection.

P9.14	1st fault type	0~51	-
P9.15	2nd fault type	0~51	-
P9.16	3rd (latest) fault type	0~51	-



It is used to record the types of the most recent three faults of the Inverter. 0 indicates no fault. For possible causes and solution of each fault, refer to Chapter 6.

Fault types:

Number	Fault display	Fault type
0	No	No fault
1	1=E.IGbt	IGBT protection
2	2=E.oCAC	Acceleration over current
3	3=E.oCdE	Ceeleration over current
4	4=E.oCCo	Constant speed over current
5	5=E.oUAC	Acceleration over voltage
6	6=E.oUdE	Deceleration over voltage
7	7=E.oUCo	Constant speed over voltage
8	8=E.CPF	Control power fault
9	9=E.LU	Under voltage fault
10	10=E.oL1	Inverter overload
11	11=E.oLt	Motor overload
12	12=I.PHO	Input phase loss
13	13=O.PHo	Output phase loss
14	14=E.oH1	Module overheat
15	15=E.EIoF	External fault
16	16=E.CoF1	Communication fault
17	17=E.rECF	Contactoer fault
18	18=E.HALL	Current detection fault
19	19=E.tUnE	Motor tuning fault
20	20=E.PG1	Encoder fault
21	21=E.EEP	EEPROM read & write fault
22	22=E.HARd	Inverter hardware fault
23	23=E.SHot	Grounding fault
24	No	Reserved
25	No	Reserved
26	26=E.ArA	Accumulative running time reached fault
27	27=E.US11	User defined fault 1

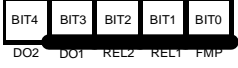
28	28=E.USI2	User defined fault2
29	29=E.APA	Power-on timereached
30	30=E.ULF	Load becoming 0 fault
31	31=E.PID	PID feedback lost duringrunning
40	40=E.CbC	IGBT current limiting fault
41	41=E.tSr	Running motor switchover fault
42	42=E.SdL	Speed deviation too large
43	43=E.oSF	Motor over speed
45	45=E.oHt	Motor over heat
51	51=E.PoSF	Initial position fault

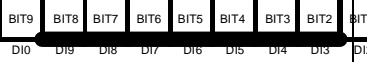
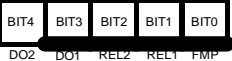
P9.17	Frequency upon 3rd fault	It displays the frequency when the latest fault occurs.	
P9.18	Current upon 3rd fault	It displays the current when the latest fault occurs.	
P9.19	Bus voltage upon 3rd fault	It displays the bus voltage when the latest fault occurs.	
P9.20	DI status upon 3rd fault	<p>It displays the status of all DI terminals when the latest fault occurs.</p> <p>The sequence is as follows:</p>  <p>If a DI is ON, the setting is 1. If the DI is OFF, the setting is 0. The value is the equivalent decimal number converted from the DI status.</p>	
P9.21	Output terminal status upon 3rd fault	<p>It displays the status of all output terminals when the latest fault occurs.</p> <p>The sequence is as follows:</p>  <p>If an output terminal is ON, the setting is 1. If the output terminal is OFF, the setting is 0. The value is the equivalent decimal number converted from the DI statuses.</p>	
P9.22	3rd fault inverter status	Reserved	
P9.23	Power-on time upon 3rd fault	It displays the present power-on time when the latest fault occurs.	
P9.24	Running time upon 3rd fault	It displays the present running time when the latest fault occurs.	
P9.27	Frequency upon 2nd fault	It displays the frequency when the latest fault occurs.	

P9.28	Current upon 2nd fault	It displays the current when the latest fault occurs.	
P9.29	Bus voltage upon 2nd fault	It displays the bus voltage when the latest fault occurs.	
P9.30	DI status upon 2nd fault	<p>It displays the status of all DI terminals when the latest fault occurs.</p> <p>The sequence is as follows:</p>  <p>If a DI is ON, the setting is 1. If the DI is OFF, the setting is 0. The value is the equivalent decimal number converted from the DI status.</p>	
P9.31	Output terminal status upon 2nd fault	<p>It displays the status of all output terminals when the latest fault occurs.</p> <p>The sequence is as follows:</p>  <p>If an output terminal is ON, the setting is 1. If the output terminal is OFF, the setting is 0. The value is the equivalent decimal number converted from the DI statuses.</p>	
P9.32	2nd fault inverter status	Reserved	
P9.33	Power-on time upon 2nd fault	It displays the present power-on time when the latest fault occurs.	
P9.34	Running time upon 2nd fault	It displays the present running time when the latest fault occurs.	
P9.37	Frequency upon 1st fault	It displays the frequency when the latest fault occurs.	
P9.38	Current upon 1st fault	It displays the current when the latest fault occurs.	
P9.39	Bus voltage upon 1st fault	It displays the bus voltage when the latest fault occurs.	
P9.40	DI status upon 1st fault	<p>It displays the status of all DI terminals when the latest fault occurs.</p> <p>The sequence is as follows:</p>  <p>If a DI is ON, the setting is 1. If the DI is OFF, the setting is 0. The value is the equivalent decimal number converted from the DI status.</p>	

P9.41	Output terminal status upon 1st fault	<p>It displays the status of all output terminals when the latest fault occurs.</p> <p>The sequence is as follows:</p> <table border="1" style="margin-left: auto; margin-right: auto;"> <tr> <td>BIT4</td> <td>BIT3</td> <td>BIT2</td> <td>BIT1</td> <td>BIT0</td> </tr> <tr> <td>DO2</td> <td>DO1</td> <td>REL2</td> <td>REL1</td> <td>FMP</td> </tr> </table> <p>If an output terminal is ON, the setting is 1. If the output terminal is OFF, the setting is 0. The value is the equivalent decimal number converted from the DI statuses.</p>	BIT4	BIT3	BIT2	BIT1	BIT0	DO2	DO1	REL2	REL1	FMP	
BIT4	BIT3	BIT2	BIT1	BIT0									
DO2	DO1	REL2	REL1	FMP									
P9.42	1st fault inverter status	Reserved											
P9.43	Power-on time upon 1st fault	It displays the present power-on time when the latest fault occurs.											
P9.44	Running time upon 1st fault	It displays the present running time when the latest fault occurs.											
P9.47	Fault protection action selection 1	One's place	Motor overload (11=E.oLt)	0000									
		Coast to stop			0								
		Stop according to stop mode			1								
		Continue to run			2								
		Ten's place	Input phase loss (12=E.IPho)										
		Coast to stop			0								
		Stop according to stop mode			1								
		Hundred's place	Output phase loss(13=E.oPho)										
		Coast to stop			0								
		Stop according to stop mode			1								
		Thousand's place	External fault (15=E.EIOF)										
		Coast to stop			0								
		Stop according to stop mode			1								
		Ten thousand's place	Communication fault (16=E.CoF1)										
		Coast to stop			0								
		Stop according to stop mode			1								

P9.48	Fault protection action selection 2	One's place	Encoder fault (20=E.PG1)	000 00		
		Coast to stop			0	
		Switch to V/F mode and stop according to stop mode			1	
		Switch to V/F mode and continue to run			2	
		Ten's place	EEPROM fault (21=E.EEP)			
		Coast to stop			0	
		Stop according to stop mode			1	
		Hundred's place	reserved			
		Thousand's place	Motor overheat (45= E.oHt)			
		Coast to stop			0	
		Stop according to stop mode			1	
		Continue to run			2	
		Ten thousand's place	Accumulative running time reached (26= E.ArA)			
		Coast to stop			0	
		Stop according to stop mode			1	
		Continue to run			2	
P9.49	Fault protection action selection 3	One's place	User defined fault 1 (27= E.USt1)	000 00		
		Coast to stop			0	
		Stop according to stop mode			1	
		Continue to run			2	
		Ten's place	User defined fault 2(28= E.USt2)			
		Coast to stop			0	
		Stop according to stop mode			1	
		Continue to run			2	
		Hundred's place	Accumulative power-on time reached (29= E.APA)			

P9.50	Fault protection action selection 4	Coast to stop	0		
		Stop according to stop mode	1		
		Continue to run	2		
		Ten thousand's place	Load becoming 0 (30= E. ULF)		
		Coast to stop	0		
		Stop according to stop mode	1		
		Continue to run at 7% of rated motor frequency and resume to the set frequency if the load recovers	2		
		Ten thousand's place	PID feedback lost during running (31= E.PID)		
		Coast to stop	0		
		Stop according to stop mode	1		
		Continue to run	2		
		One's place	Speed deviation too large (42= E.SdL)	0000	
		Coast to stop	0		
		Stop according to stop mode	1		
		Continue to run	2		
Ten's place	Motor over speed (43= E.oSF)				
Coast to stop	0				
Stop according to stop mode	1				
Continue to run	2				
Hundred's place	Initial position fault (51= E.PoSf)				
Coast to stop	0				
Stop according to stop mode	1				
Continue to run	2				

If "Coast to stop" is selected, the Inverter displays E.**** and directly stops.

If "Stop according to the stop mode" is selected, the Inverter displays A.**** and stops according to the stop mode. After stop, the Inverter displays E.****.

If "Continue to run" is selected, the Inverter continues to run and displays A.****. The running frequency is set in P9.54.

P9.54	Frequency selection for continuing to run upon fault	Current running frequency	0	0
		Set frequency	1	
		Frequency upper limit	2	
		Frequency lower limit	3	
		Backup frequency upon abnormality	4	
P9.55	Backup frequency upon abnormality	60.0%~100.0%	100.0%	

If a fault occurs during the running of the Inverter and the handling of fault is set to "Continue to run", the Inverter displays A.** and continues to run at the frequency set in P9.54.

The setting of P9.55 is a percentage relative to the maximum frequency..

P9.56	Type of motor temperature sensor	No temperature sensor	0	0
		PT100	1	
		PT1000	2	
P9.57	Motor overheat protection threshold	0 ~200	110	
P9.58	Motor overheat warning threshold	0 ~200	90	

The signal of the motor temperature sensor needs to be connected to the optional I/O extension card. AI3x on the extension card can be used for the temperature signal input. The motor temperature sensor is connected to AI3 and PGND of the extension card. The AI3 terminal of the DLB1 supports both PT100 and PT1000. Set the sensor type correctly during the use. You can view the motor temperature via d0.34.

If the motor temperature exceeds the value set in P9.57, the Inverter reports an alarm and acts according to the selected fault protection action.

If the motor temperature exceeds the value set in P9.58, the DO terminal on the Inverter allocated with function 39 (Motor overheat warning) becomes ON.

P9.59	Action selection at instantaneous power failure	Invalid	0	0
		Decelerate	1	
		Decelerate to stop	2	
P9.60	Action pause judging voltage at instantaneous power failure	80.0%~100.0%	90.0%	
P9.61	Voltage rally judging time at instantaneous power failure	0.00s~100.00s	0.50s	
P9.62	Action judging voltage at instantaneous power failure	60.0%~100.0%(standard bus voltage)	80.0%	

Upon instantaneous power failure or sudden voltage dip, the DC bus voltage of the Inverter reduces. This function enables the Inverter to compensate the DC bus voltage reduction with the load feedback energy by reducing the output frequency so as to keep the Inverter running continuously.

- If P9.59 = 1, upon instantaneous power failure or sudden voltage dip, the Inverter decelerates. Once the bus voltage resumes to normal, the Inverter accelerates to the set frequency. If the bus voltage remains normal for the time exceeding the value set in P9.61, it is considered that the bus voltage resumes to normal.
- If P9.59 = 2, upon instantaneous power failure or sudden voltage dip, the Inverter decelerates to stop.

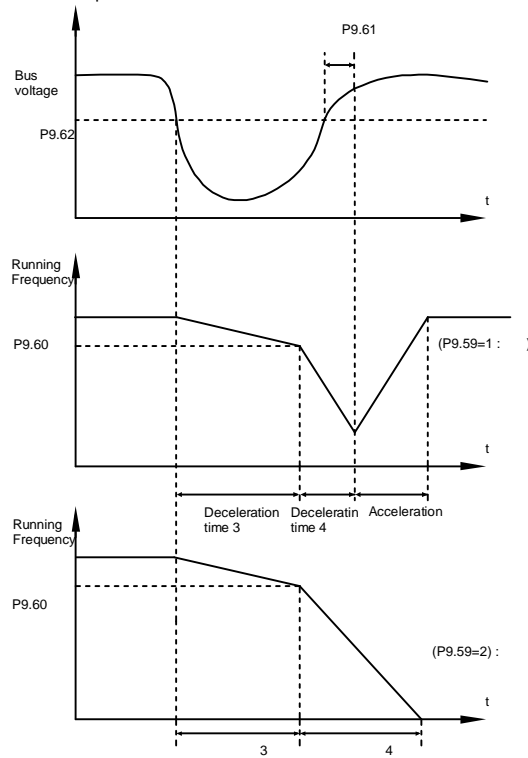

P9.63	Protection upon load becoming 0	Disabled	0	0
		Enabled	1	
P9.64	Detection level of load becoming 0	0.0%~100.0%(motorrated current)	10.0%	
P9.65	Detection time of load becoming 0	0.0s~60.0s	1.0s	

If protection upon load becoming 0 is enabled, when the output current of the Inverter is lower than the detection level (P9.64) and the lasting time exceeds the detection time (P9.65), the output frequency of the Inverter automatically declines to 7% of the rated frequency. During the protection, the Inverter automatically accelerates to the set frequency if the load resumes to

normal.				
P9.67	Over-speed detection value	0.0%~50.0%(maximum frequency)	20.0%	
P9.68	Over-speed detection time	0.0s~60.0s	1.0s	

This function is valid only when the Inverter runs in the FVC mode.

If the actual motor rotational speed detected by the Inverter exceeds the maximum frequency and the excessive value is greater than the value of P9.67 and the lasting time exceeds the value of P9.68, the Inverter reports 43=E.oSF and acts according to the selected fault protection action.

If the over-speed detection time is 0.0s, the over-speed detection function is disabled.

P9.69	Detection value of too large speed deviation	0.0%~50.0%(maximum frequency)	20.0%	
P9.70	Detection time of too large speed deviation	0.0s~60.0s	5.0s	

This function is valid only when the Inverter runs in the FVC mode.

If the Inverter detects the deviation between the actual motor rotational speed detected by the Inverter and the set frequency is greater than the value of P9.69 and the lasting time exceeds the value of P9.70, the Inverter reports 42=E.Sdl and according to the selected fault protection action.

If P9.70 (Detection time of too large speed deviation) is 0.0s, this function is disabled.

4.12 PID functions:PA.00-PA.28

PID control is a general process control method. By performing proportional, integral and differential operations on the difference between the feedback signal and the target signal, it adjusts the output frequency and constitutes a feedback system to stabilize the controlled counter around the target value.

It is applied to process control such as flow control, pressure control and temperature control. The following figure shows the principle block diagram of PID control.

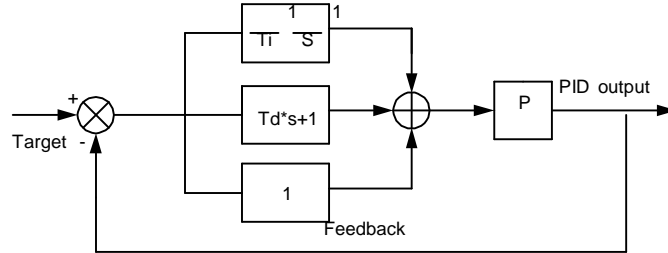

Code	Description	Setting range		Default	Restrictions
PA.00	PID setting source	PA.01 setting	0	0	
		A11	1		
		A12	2		
		A13(keyboard potentiometer)	3		
		Pulse(DI5)	4		
		Communication setting	5		
		Multi-reference	6		
PA.01	PID digital setting	0.0%~100.0%		50.0%	

PA.00 is used to select the channel of target process PID setting. The PID setting is a relative value and ranges from 0.0% to 100.0%. The PID feedback is also a relative value. The purpose of PID control is to make the PID setting and PID feedback equal.

PA.02	PID feedback source	A11	0	0	
		A12	1		
		A13(keyboard potentiometer)	2		
		Pulse(DI5)	3		
		Communication setting	4		
		A11	5		
		A11+A12	6		
		MAX(A11 , A12)	7		

		MIN(AI1 , AI2)	8	
This parameter is used to select the feedback signal channel of process PID. The PID feedback is a relative value and ranges from 0.0% to 100.0%.				

PA.03	PID action direction	Forward action	0	0
		Reverse action	1	

- 0: Forward action

When the feedback value is smaller than the PID setting, the Inverter's output frequency rises. For example, the winding tension control requires forward PID action.

- 1: Reverse action

When the feedback value is smaller than the PID setting, the Inverter's output frequency reduces. For example, the unwinding tension control requires reverse PID action.

Note that this function is influenced by the DI function 35 "Reverse PID action direction"

PA.04	PID feedback range	0~65535	1000	
-------	--------------------	---------	------	--

This parameter is a non-dimensional unit. It is used for PID setting display (d0.15) and PID feedback display (U0-16).

Relative value 100% of PID setting feedback corresponds to the value of PA.04. If PA.04 is set to 2000 and PID setting is 100.0%, the PID setting display (d0.15) is 2000.

PA.05	Proportional gain K_{p1}	0.0~100.0	20.0	
PA.06	Integral time T_{i1}	0.01s~10.00s	2.00s	
PA.07	Differential time T_{d1}	0.00~10.000	0.000s	

proportional gain K_{p1} :

It decides the regulating intensity of the PID regulator. The higher the K_{p1} is, the larger the regulating intensity is. The value 100.0 indicates when the deviation between PID feedback and PID setting is 100.0%, the adjustment amplitude of the PID regulator on the output frequency reference is the maximum frequency.

integral time T_{i1} :

It decides the integral regulating intensity. The shorter the integral time is, the larger the regulating intensity is. When the deviation between PID feedback and PID setting is 100.0%, the integral regulator performs continuous adjustment for the time set in PA. 06. Then the adjustment amplitude reaches the maximum frequency.

differential time T_{d1} :

It decides the regulating intensity of the PID regulator on the deviation change. The longer the differential time is, the larger the regulating intensity is. Differential time is the time within which the feedback value change reaches 100.0%, and then the adjustment amplitude reaches the maximum frequency.

PA.08	Cut-off frequency of PID reverse rotation	0.00~ maximum frequency	2.00Hz	
-------	---	-------------------------	--------	--

In some situations, only when the PID output frequency is a negative value (Inverter reverse rotation), PID setting and PID feedback can be equal. However, too high reverse rotation frequency is prohibited in some applications, and PA.08 is used to determine the reverse rotation frequency upper limit.

PA.09	PID deviation limit	0.0%~100.0%	0.0%	
<p>If the deviation between PID feedback and PID setting is smaller than the value of PA.09, PID control stops. The small deviation between PID feedback and PID setting will make the output frequency stabilize, effective for some closed-loop control applications.</p>				
PA.10	PID differential limit	0.00%~100.00%	0.10%	
<p>It is used to set the PID differential output range. In PID control, the differential operation may easily cause system oscillation. Thus, the PID differential regulation is restricted to a small range.</p>				
PA.11	PID setting change time	0.00s~650.00s	0.00s	
<p>The PID setting change time indicates the time required for PID setting changing from 0.0% to 100.0%. The PID setting changes linearly according to the change time, reducing the impact caused by sudden setting change on the system.</p>				
PA.12	PID feedback filter time	0.00s~60.00s	0.00s	
PA.13	PID output filter time	0.00s~60.00s	0.00s	
<p>PA.12 is used to filter the PID feedback, helping to reduce interference on the feedback but slowing the response of the process closed-loop system.</p> <p>PA.13 is used to filter the PID output frequency, helping to weaken sudden change of the Inverter output frequency but slowing the response of the process closed-loop system.</p>				
PA.14	Reserved	-	-	-
PA.15	Proportional gain K_{p2}	0.0~100.0	20.0	
PA.16	Integral time T_{i2}	0.01s~10.00s	2.00s	
PA.17	Differential time T_{d2}	0.00~10.000	0.000s	
PA.18	PID parameter switchover condition	No switchover	0	0
		Switchover via DI	1	
		Automatic switchover based on deviation	2	
PA.19	PID parameter switchover deviation 1	0.0%~PA.20	20.0%	
PA.20	PID parameter switchover deviation 2	PA.19~100.0%	80.0%	

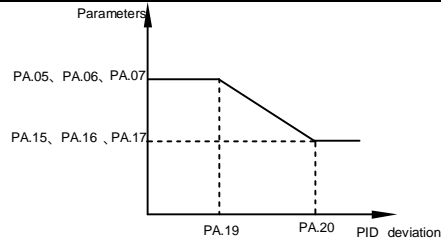

In some applications, PID parameters switchover is required when one group of PID parameters cannot satisfy the requirement of the whole running process.

These parameters are used for switchover between two groups of PID parameters. Regulator parameters PA.15 to PA.17 are set in the same way as PA.05 to PA.07.

The switchover can be implemented either via a DI terminal or automatically implemented based on the deviation.

If you select switchover via a DI terminal, the DI must be allocated with function 43 "PID parameter switchover". If the DI is OFF, group 1 (PA.05 to PA.07) is selected. If the DI is ON, group 2 (PA.15 to PA.17) is selected.

If you select automatic switchover, when the absolute value of the deviation between PID feedback and PID setting is smaller than the value of PA.19, group 1 is selected. When the absolute value of the deviation between PID feedback and PID setting is higher than the value of PA.20, group 2 is selected. When the deviation is between PA.19 and PA.20, the PID parameters are the linear interpolated value of the two groups of parameter values.

PA.21	PID initial value	0.0%~100.0%	0.0%	
PA.22	PID initial value holding time	0.00s~650.00s	0.00s	

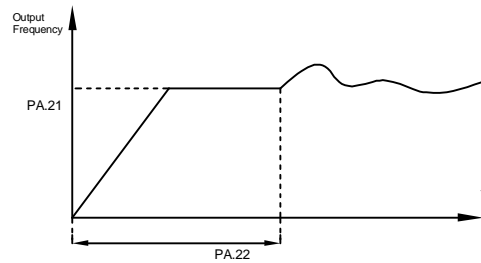

When the Inverter starts up, the PID starts closed-loop algorithm only after the PID output is fixed to the PID initial value (PA.21) and lasts the time set in PA.22.

This function is used to limit the deviation between two PID outputs (2 ms per PID output) to suppress the rapid change of PID output and stabilize the running of the Inverter.

PA.23	Maximum deviation between two PID outputs in forward direction	0.00%~100.00%	1.00%	
-------	--	---------------	-------	--

PA.24	Maximum deviation between two PID outputs in reverse direction	0.00%~100.00%	1.00%	
-------	--	---------------	-------	--

PA.23 and PA.24 respectively correspond to the maximum absolute value of the output deviation in forward direction and in reverse direction.

PA.25	PID integral property	One's place	Integral separated		00
		Invalid	0		
		Valid	1		
		Ten's place	Whether to stop integral operation when the output reaches the limit		
		Continue integral	0		
		Stop integral	1		

- Integral separated

If it is set to valid, , the PID integral operation stops when the DI allocated with function 38 "PID integral pause" is ON In this case, only proportional and differential operations take effect.

If it is set to invalid, integral separated remains invalid no matter whether the DI allocated with function 38 "PID integral pause" is ON or not.

- Whether to stop integral operation when the output reaches the limit

If "Stop integral operation" is selected, the PID integral operation stops, which may help to reduce the PID overshoot

PA.26	Detection value of PID feedback loss	Not judging feedback loss	0.0%	0.0%	
		0.1%~100.0%	0.1%		
PA.27	Detection time of PID feedback loss	0.0s~20.0s		0s	

These parameters are used to judge whether PID feedback is lost.

If the PID feedback is smaller than the value of PA.26 and the lasting time exceeds the value of PA.27, the Inverter reports Err31 and acts according to the selected fault protection action.

PA.28	PID operation at stop	No PID operation at stop	0	0
		PID operation at stop	1	

It is used to select whether to continue PID operation in the state of stop. Generally, the PID operation stops when the Inverter stops.

4.13 Swing Frequency, Fixed Length and Count:PB.00-PB.09

The swing frequency function is applied to the textile and chemical fiber fields and the applications where traversing and winding functions are required.

The swing frequency function indicates that the output frequency of the Inverter swings up and down with the set frequency as the center. The trace of running frequency at the time axis is shown in the following figure.

The swing amplitude is set in PB.00 and PB.01. When PB.01 is set to 0, the swing amplitude is 0 and the swing frequency does not take effect.

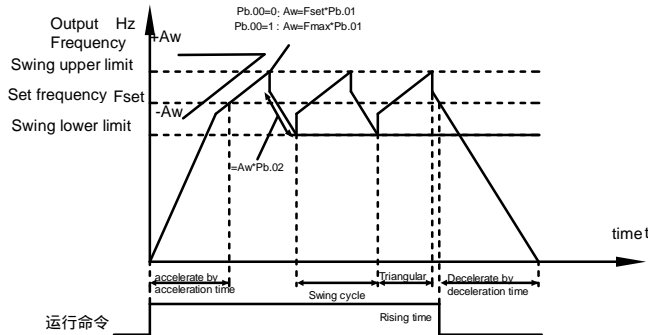

Code	Description	Setting range		Default	Restrictions
PB.00	Swing frequency setting mode	Relative to the central frequency	0	0	
		Relative to the maximum frequency	1		
PB.01	Swing frequency amplitude	0.0%~100.0%		0.0%	
PB.02	Jump frequency amplitude	0.0%~50.0%		0.0%	

- 0: Relative to the central frequency (P0.07 frequency source selection)
It is variable swing amplitude system. The swing amplitude varies with the central frequency (set frequency).
 - 1: Relative to the maximum frequency (P0.10 maximum output frequency)
It is fixed swing amplitude system. The swing amplitude is fixed.
- This parameter is used to determine the swing amplitude and jump frequency amplitude. The swing frequency is limited by the frequency upper limit and frequency lower limit.
- If relative to the central frequency (PB.00 = 0), the actual swing amplitude AW is the calculation result of P0.07 (Frequency source selection) multiplied by PB.01.
 - If relative to the maximum frequency (PB.00 = 1), the actual swing amplitude AW is the calculation result of P0.10 (Maximum frequency) multiplied by PB.01.
- Jump frequency = Swing amplitude AW x PB.02 (Jump frequency amplitude).
- If relative to the central frequency (PB.00 = 0), the jump frequency is a variable value.

<ul style="list-style-type: none"> If relative to the maximum frequency (PB.00 = 1), the jump frequency is a fixed value. The swing frequency is limited by the frequency upper limit and frequency lower limit. 				
PB.03	Swing frequency cycle	0.0s~3000.0s	10.0s	
PB.04	Triangular wave rising time coefficient	0.0%~100.0%	50.0%	

PB.03 specifies the time of a complete swing frequency cycle.

PB.04 specifies the time percentage of triangular wave rising time to PB.03 (Swing frequency cycle).

- Triangular wave rising time = PB.03 (Swing frequency cycle) x PB.04 (Triangular wave rising time coefficient, unit: s)

- Triangular wave falling time = PB.03 (Swing frequency cycle) x (1 - PB.04 Triangular wave rising time coefficient, unit: s)

PB.05	Set length	0m~65535m	1000m	
PB.06	Actual length	0m~65535m	0m	
PB.07	Number of pulses per meter	0.1~6553.5	100.0	

The preceding parameters are used for fixed length control.

The length information is collected by DI terminals. PB.06 (Actual length) is calculated by dividing the number of pulses collected by the DI terminal by PB.07 (Number of pulses each meter).

When the actual length PB.06 exceeds the set length in PB.05, the DO terminal allocated with function 10 (Length reached) becomes ON.

During the fixed length control, the length reset operation can be performed via the DI terminal allocated with function 28. For details, see the descriptions of P4.00 to P4.09.

Allocate corresponding DI terminal with function 27 (Length count input) in applications. If the pulse frequency is high, DI5 must be used.

PB.08	Set count value	1~65535	1000	
PB.09	Designated count value	1~65535	1000	

The count value needs to be collected by DI terminal. Allocate the corresponding DI terminal with function 25 (Counter input) in applications. If the pulse frequency is high, DI5 must be used.

When the count value reaches the set count value (PB.08), the DO terminal allocated with function 8 (Set count value reached) becomes ON. Then the counter stops counting.

When the counting value reaches the designated counting value (PB.09), the DO terminal

allocated with function 9 (Designated count value reached) becomes ON. Then the counter continues to count until the set count value is reached.

PB.09 should be equal to or smaller than PB.08.

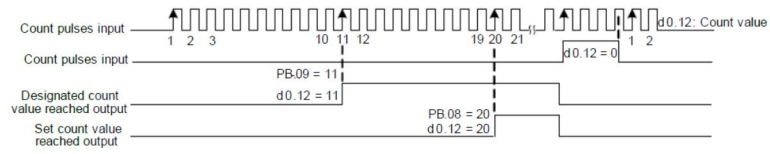

4.14 Multi-reference and simple PLC:PC.00-PC.51

The DLB1 multi-reference has many functions. Besides multi-speed, it can be used as the setting source of the V/F separated voltage source and setting source of process PID. In addition, the multi-reference is relative value.

Code	Description	Setting range	Default	Restrictions
PC.00	Multi-reference 0	-100.0%~100.0%	0.0%	
PC.01	Multi-reference 1	-100.0%~100.0%	0.0%	
PC.02	Multi-reference 2	-100.0%~100.0%	0.0%	
PC.03	Multi-reference 3	-100.0%~100.0%	0.0%	
PC.04	Multi-reference 4	-100.0%~100.0%	0.0%	
PC.05	Multi-reference 5	-100.0%~100.0%	0.0%	
PC.06	Multi-reference 6	-100.0%~100.0%	0.0%	
PC.07	Multi-reference 7	-100.0%~100.0%	0.0%	
PC.08	Multi-reference 8	-100.0%~100.0%	0.0%	
PC.09	Multi-reference 9	-100.0%~100.0%	0.0%	
PC.10	Multi-reference 10	-100.0%~100.0%	0.0%	
PC.11	Multi-reference 11	-100.0%~100.0%	0.0%	
PC.12	Multi-reference 12	-100.0%~100.0%	0.0%	
PC.13	Multi-reference 13	-100.0%~100.0%	0.0%	
PC.14	Multi-reference 14	-100.0%~100.0%	0.0%	
PC.15	Multi-reference 15	-100.0%~100.0%	0.0%	

Multi-reference can be the setting source of frequency, V/F separated voltage and process PID. The multi-reference is relative value and ranges from -100.0% to 100.0%.

As frequency source, it is a percentage relative to the maximum frequency. As V/F separated voltage source, it is a percentage relative to the rated motor voltage. As process PID setting source, it does not require conversion.

Multi-reference can be switched over based on different states of DI terminals. For details, see the descriptions of group P4

PC.16	Simple PLCrunning mode	Stop after the Inverter runs one cycle	0	0
		Keep final values after the Inverter runs one cycle	1	
		Repeat after the Inverter runs one cycle	2	

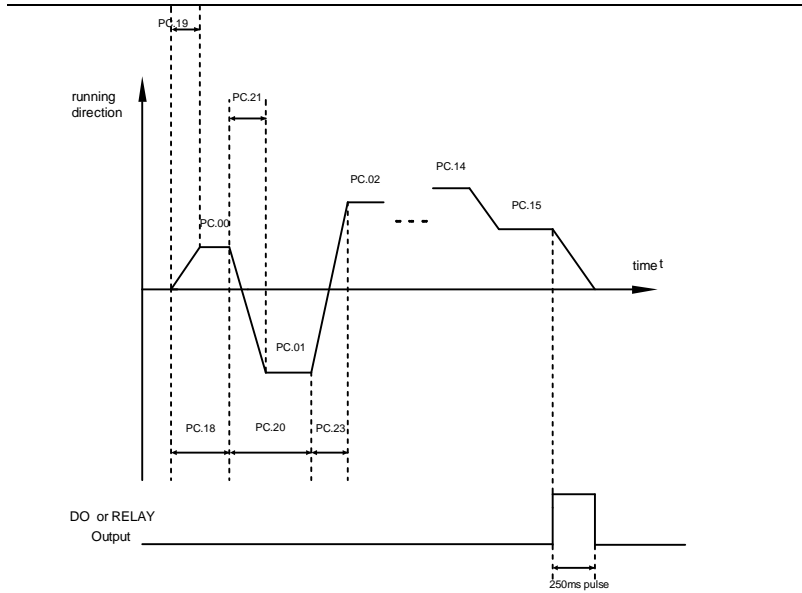

- 0: Stop after the Inverter runs one cycle
The Inverter stops after running one cycle, and will not start up until receiving another command.
- 1: Keep final values after the Inverter runs one cycle
The Inverter keeps the final running frequency and direction after running one cycle.
- 2: Repeat after the Inverter runs one cycle
The Inverter automatically starts another cycle after running one cycle, and will not stop until receiving the stop command.

Simple PLC can be either the frequency source or V/F separated voltage source.
When simple PLC is used as the frequency source, whether parameter values of PC.00 to PC.15 are positive or negative determines the running direction. If the parameter values are negative, it indicates that the Inverter runs in reverse direction.

PC.17	Simple PLC retentive selection upon power failure	One's place	Retentive upon power failure	00
		No		0
		Yes		1
		Ten's place	Retentive upon stop	
		No		0
		Yes		1

PLC retentive upon power failure indicates that the Inverter memorizes the PLC running moment

and running frequency before power failure and will continue to run from the memorized moment after it is powered on again. If the unit's digit is set to 0, the Inverter restarts the PLC process after it is powered on again.

PLC retentive upon stop indicates that the Inverter records the PLC running moment and running frequency upon stop and will continue to run from the recorded moment after it starts up again. If the ten's digit is set to 0, the Inverter restarts the PLC process after it starts up again.

PC.18	Running time of simple PLC reference 0	0.0s(h)~6553.5s(h)	0.0s(h)	
PC.19	Acceleration/deceleration time of simple PLC reference 0	0~3	0	
PC.20	Running time of simple PLC reference 1	0.0s(h)~6553.5s(h)	0.0s(h)	
PC.21	Acceleration/deceleration time of simple PLC reference 1	0~3	0	
PC.22	Running time of simple PLC reference 2	0.0s(h)~6553.5s(h)	0.0s(h)	
PC.23	Acceleration/deceleration time of simple PLC reference 2	0~3	0	
PC.24	Running time of simple PLC reference 3	0.0s(h)~6553.5s(h)	0.0s(h)	
PC.25	Acceleration/deceleration time of simple PLC reference 3	0~3	0	
PC.26	Running time of simple PLC reference 4	0.0s(h) ~6553.5s(h)	0.0s(h)	
PC.27	Acceleration/deceleration time of simple PLC reference 4	0~3	0	
PC.28	Running time of simple PLC reference 5	0.0s(h) ~6553.5s(h)	0.0s(h)	
PC.29	Acceleration/deceleration time of simple PLC reference 5	0~3	0	
PC.30	Running time of simple PLC reference 6	0.0s(h) ~6553.5s(h)	0.0s(h)	
PC.31	Acceleration/deceleration time of simple PLC reference 6	0~3	0	

PC.32	Running time of simple PLC reference 7	0.0s(h) ~6553.5s(h)	0.0s(h)	
PC.33	Acceleration/deceleration time of simple PLC reference 7	0~3	0	
PC.34	Running time of simple PLC reference 8	0.0s(h) ~6553.5s(h)	0.0s(h)	
PC.35	Acceleration/deceleration time of simple PLC reference 8	0~3	0	
PC.36	Running time of simple PLC reference 9	0.0s(h)~6553.5s(h)	0.0s(h)	
PC.37	Acceleration/deceleration time of simple PLC reference 9	0~3	0	
PC.38	Running time of simple PLC reference 10	0.0s(h)~6553.5s(h)	0.0s(h)	
PC.39	Acceleration/deceleration time of simple PLC reference 10	0~3	0	
PC.40	Running time of simple PLC reference 11	0.0s(h)~6553.5s(h)	0.0s(h)	
PC.41	Acceleration/deceleration time of simple PLC reference 11	0~3	0	
PC.42	Running time of simple PLC reference 12	0.0s(h)~6553.5s(h)	0.0s(h)	
PC.43	Acceleration/deceleration time of simple PLC reference 12	0~3	0	
PC.44	Running time of simple PLC reference 13	0.0s(h) ~6553.5s(h)	0.0s(h)	
PC.45	Acceleration/deceleration time of simple PLC reference 13	0~3	0	
PC.46	Running time of simple PLC reference 14	0.0s(h)~6553.5s(h)	0.0s(h)	
PC.47	Acceleration/deceleration time of simple PLC reference 14	0~3	0	

PC.48	Running time of simple PLC reference 15	0.0s(h)~6553.5s(h)	0.0s(h)	
PC.49	Acceleration/deceleration time of simple PLC reference 15	0~3	0	
PC.50	Time unit of simple PLC running	s(s)	0	0
		h(hour)	1	
PC.51	Reference 0 source	PC.00 setting	0	0
		A11	1	
		A12	2	
		A13(keyboard potentiometer)	3	
		Pulse setting	4	
		PID	5	
		Set by preset frequency (P0.08), modified via terminal UP/DOWN	6	

It determines the setting channel of reference 0. You can perform convenient switchover between the setting channels. When multi-reference or simple PLC is used as frequency source, the switchover between two frequency sources can be realized easily.

4.15 Communication parameters:PD.00-PD.06

Please refer toDLB1 communication protocol

Code	Description	Setting range	Default	Restrictions		
PD.00	Bit rate	One's place MODBUS	6005			
		300BPS			0	
		600BPS			1	
		1200BPS			2	
		2400BPS			3	
		4800BPS			4	
		9600BPS			5	
		19200BPS			6	
		38400BPS			7	
		57600BPS			8	
		115200BPS			9	
		Ten's place Profibus-DP			0	
		115200BPS				
		208300BPS	1			
		256000BPS	2			
					512000BPS	3
		Hundred's place Reserved				
		Thousand's place CANlink bit rate				
					20	0
					50	1
		100	2			
		125	3			
		250	4			
		500	5			
		1M	6			
PD.01	Data type	8-N-2	0	0		
		8-E-1	1			
		8-O-1	2			
		8-N-1	3			

PD.02	This device address	1-247, 0 is master station address	1		
PD.03	Response delay	0ms-20ms	2		
PD.04	Communication over-time	0.0(invlaid), 0.1s-60.0s	0.0		
PD.05	Data transfer format	One's place	MODBUS	30	
		Non-standard MODBUS protocol		0	
		Standard MODBUS protocol		1	
		Ten's place	Profibus-DP		
		PPO1 format		0	
		PPO2format		1	
		PPO3format		2	
		PPO5format		3	
PD.06	Current resolution	0.01A	0	0	
		0.1A	1		

4.16 PE group: reserved

4.17 Function code management:PP.00-PP.04

Code	Description	Setting range	Default	Restrictions
PP.00	User password	0-65535	0	

If it is set to any non-zero number, the password protection function is enabled. After a password has been set and taken effect, you must enter the correct password in order to enter the menu. If the entered password is incorrect you cannot view or modify parameters.

If PP.00 is set to 00000, the previously set user password is cleared, and the password protection function is disabled.

PP.01	Parameter initialization	No operation	0	0
		Restore factory settings except motorparameters	1	
		Clear records	2	
		Restore factory settings including motor parameters	3	
		Backup current user parameters to control board memory	4	
		Backup current user parameters to keyboard memory 1	5	
		Backup current user parameters to keyboard memory2	6	

		Use control board memory to restore parameters	501		
		Use keyboard memory 1 to restore parameters	502		
		Use keyboard memory 2 to restore parameters	503		

- 1: Restore default settings except motor parameters

If PP.01 is set to 1, most function codes are restored to the default settings except motor parameters, frequency reference resolution (P0.22), fault records, accumulative running time (P7.09), accumulative power-on time (P7.13) and accumulative power consumption (P7.14).

- 2: Clear records

If PP.01 is set to 2, the fault records, accumulative running time (P7.09), accumulative power-on time (P7.13) and accumulative power consumption (P7.14) are cleared.

- 3: Restore factory settings including motor parameters

If PP.01 is set to 3, most function codes are restored to the default settings including motor parameters.

- 4: Backup current user parameters to control board memory

If PP.01 is set to 4, the current parameter settings are backed up in control board memory, helping you to restore the setting if incorrect parameter setting is performed.

- 5: Backup current user parameters to keyboard memory 1

- 6: Backup current user parameters to keyboard memory2

- 501: Use control board memory to restore parameters

If PP.01 is set to 4, the previous backup user parameters in control board memory are restored.

- 502: Use keyboard memory 1 to restore parameters

- 503: Use keyboard memory 2 to restore parameters

PP.02	Inverterparameter display property	One's place	Group d display selection	01	
			No display	0	
			Display	1	
		Ten's place	Group b display selection		
			No display	0	
			Display	1	
PP.04	Parameter modification property		Modifiable	0	0
			Not modifiable	1	

It is used to set whether the parameters are modifiable to avoid mal-function. If it is set to 0, all parameters are modifiable. If it is set to 1, all parameters can only be viewed.

4.18 Torque control parameters: B0.00-B0.08

Code	Description	Setting range	Default	Restrictions
B0.00	Speed/Torque control selection	Speed control	0	0
		Torque control	1	

It is used to select the Inverter's control mode: speed control or torque control.

The DLB1 provides DI terminals with two torque related functions, function 29 (Torque control prohibited) and function 46 (Speed control/Torque control switchover). The two DI terminals need to be used together with B0.00 to implement speed control/torque control switchover.

If the DI terminal allocated with function 46 (Speed control/Torque control switchover) is OFF, the control mode is determined by B0.00. If the DI terminal allocated with function 46 is ON, the control mode is reverse to the value of B0.00.

However, if the DI terminal with function 29 (Torque control prohibited) is ON, the Inverter is fixed to run in the speed control mode.

B0.01	Torque setting source in torque control	Digital setting(B0.03)	0	0
		A11	1	
		A12	2	
		A13(keyboard potentiometer)	3	
		Pulse	4	
		Communication setting	5	
		MIN(A11, A12)	6	
		MAX(A11, A12)	7	
B0.03	Torque digital setting in torque control	-200.0%~200.0%	150%	

B0.01 is used to set the torque setting source. There are a total of eight torque setting sources.

The torque setting is a relative value. 100.0% corresponds to the Inverter's rated torque. The setting range is -200.0% to 200.0%, indicating the Inverter's maximum torque is twice of the Inverter's rated torque.

If the torque setting is positive, the Inverter rotates in forward direction. If the torque setting is negative, the Inverter rotates in reverse direction.

B0.05	Forward maximum frequency in torque control	0.00Hz~ maximum frequency(P0.10)	50.00Hz	
B0.06	Reverse maximum frequency in torque control	0.00Hz~ maximum frequency(P0.10)	50.00Hz	

These two parameters are used to set the maximum frequency in forward or reverse rotation in torque control mode.

In torque control, if the load torque is smaller than the motor output torque, the motor's rotational speed will rise continuously. To avoid runaway of the mechanical system, the motor maximum rotating speed must be limited in torque control.

You can implement continuous change of the maximum frequency in torque control dynamically by controlling the frequency upper limit.

B0.07	Acceleration time in torque control	0.00s~65000s	0.00s	
B0.08	Deceleration time in torque control	0.00s~65000s	0.00s	

In torque control, the difference between the motor output torque and the load torque determines the speed change rate of the motor and load. The motor rotational speed may change quickly and this will result in noise or too large mechanical stress. The setting of acceleration/deceleration time in torque control makes the motor rotational speed change softly.

However, in applications requiring rapid torque response, set the acceleration/deceleration time in torque control to 0.00s. For example, two Inverters are connected to drive the same load. To balance the load allocation, set one Inverter as master in speed control and the other as slave in torque control. The slave receives the master's output torque as the torque command and must follow the master rapidly. In this case, the acceleration/deceleration time of the slave in torque control is set to 0.0s.

4.19 Control optimization parameters: B5.00-B5.09

Code	Description	Setting range	Default	Restrictions
B5.00	DPWM switchover frequency upper limit	0.00Hz~15.00Hz	12.00Hz	

This parameter is valid only for V/F control.

It is used to determine the wave modulation mode in V/F control of asynchronous motor. If the frequency is lower than the value of this parameter, the waveform is 7-segment continuous modulation. If the frequency is higher than the value of this parameter, the waveform is 5-segment intermittent modulation.

The 7-segment continuous modulation causes more loss to switches of the Inverter but smaller current ripple. The 5-segment intermittent modulation causes less loss to switches of the Inverter but larger current ripple. This may lead to motor running instability at high frequency. Do not modify this parameter generally.

For instability of V/F control, refer to parameter P2.11. For loss to Inverter and temperature rise, refer to parameter P0.15.

B5.01	PWM modulation mode	Asynchronous modulation	0	0
		Synchronous modulation	1	

This parameter is valid only for V/F control.

Synchronous modulation indicates that the carrier frequency varies linearly with the change of the output frequency, ensuring that the ratio of carrier frequency to output frequency remains unchanged. Synchronous modulation is generally used at high output frequency, which helps improve the output voltage quality.

At low output frequency (100 Hz or lower), synchronous modulation is not required. This is because asynchronous modulation is preferred when the ratio of carrier frequency to output frequency is high.

Synchronous modulation takes effect only when the running frequency is higher than 85 Hz. If the frequency is lower than 85 Hz, asynchronous modulation is always used.

B5.02	Dead zone compensation mode selection	No compensation	0	1
		Compensation mode1	1	
		Compensation mode2	2	

Generally, you need not modify this parameter. Try to use a different compensation mode only when there is special requirement on the output voltage waveform quality or oscillation occurs on the motor.

For high power Inverter, compensation mode 2 is recommended.

B5.03	Random PWM depth	Random PWM invalid	0	0
		Valid	1~10	

The setting of random PWM depth can make the shrill motor noise softer and reduce the electromagnetic interference. If this parameter is set to 0, random PWM is invalid.

B5.04	Rapid current limit	Disabled	0	1
		Enabled	1	

The rapid current limit function can reduce the Inverter's overcurrent faults at maximum,

guaranteeing uninterrupted running of the Inverter.

However, long-time rapid current limit may cause the Inverter to overheat, which is not allowed. In this case, the Inverter will report 40=E.CbC, indicating the Inverter is overloaded and needs to stop.

B5.05	Current detection compensation	0~100	5	
-------	--------------------------------	-------	---	--

It is used to set the Inverter current detection compensation. Too large value may lead to deterioration of control performance. Do not modify it generally..

B5.06	Undervoltage threshold	60.0%~140.0%	100.0%	
-------	------------------------	--------------	--------	--

It is used to set the undervoltage threshold of 9=E.LU. The undervoltage threshold 100% of the Inverter of different voltage classes corresponds to different nominal values, as listed in the following table.

Voltage Class	Nominal Value of Undervoltage threshold
Single-phase 220 V	200 V
Three-phase 220 V	200 V
Three-phase 380 V	350 V
Three-phase 480 V	450 V
Three-phase 690 V	650 V

B5.07	SVC optimization mode selection	No optimization	0	1
		Optimization mode1	1	
		Optimization mode2	2	

1: Optimization mode 1

It is used when the requirement on torque control linearity is high.

2: Optimization mode 2

It is used for the requirement on speed stability is high.

B5.08	Dead-zone time adjustment	100%~200%	150%	
-------	---------------------------	-----------	------	--

It is only valid for 1140 V voltage class.

You can modify the value of this parameter to improve the voltage utilization rate. Too small value may system instability. Do not modify it generally.

B5.09	Overvoltage threshold	200.0V~2500.0V	810.0V	
-------	-----------------------	----------------	--------	--

It is used to set the overvoltage threshold of the Inverter. The default values of different voltage classes are listed in the following table.

Voltage Class	Default Overvoltage Threshold
Single phase 220 V	400.0 V
Three phase 220 V	400.0 V
Three phase 380 V	810.0 V
Three phase 480 V	890.0 V
Three phase 690 V	1300.0 V

4.20 Extended function parameters: B9.00-B9.09

Code	Description	Setting range	Default	Restrictions
B9.00	Load type	General	0	0
		Injection molding machine servo	1	
		Stone sawing	2	
		Rotary cutter	3	
		Pump jack	4	
		Splicer	5	
		Extruder	6	
		Pulling machine	7	

After selection corresponding load type, the inverter will configure parameters automatically.
For details please contact JADEN directly.

B9.01	User-defined parameter 0	0 ~ 65535	0	
B9.02	User-defined parameter 1	0 ~ 65535	0	
B9.03	User-defined parameter 2	0 ~ 65535	0	
B9.04	User-defined parameter 3	0 ~ 65535	0	
B9.05	User-defined parameter 4	0 ~ 65535	0	
B9.06	User-defined parameter 5	0 ~ 65535	0	
B9.07	User-defined parameter 6	0 ~ 65535	0	
B9.08	User-defined parameter 7	0 ~ 65535	0	
B9.09	User-defined parameter 8	0 ~ 65535	0	

5 Fault and solutions

5.1 Fault and solutions

The DLB1 provides a total of 51 pieces of fault information and protective functions. After a fault occurs, the Inverter implements the protection function, and displays the fault code on the operation panel (if the operation panel is available).

Before contacting JADEN for technical support, you can first determine the fault type, analyze the causes, and perform troubleshooting according to the following tables. If the fault cannot be rectified, contact the official distributor or JADEN directly.

22=E HARD is the Inverter hardware over-current or over-voltage signal. In most situations, hardware over-voltage fault causes 22=E HARD.

FaultName	Display	Possible Causes	Solutions
Inverter unit protection	1=E.Gbt	<p>1: The output circuit is grounded or shortcircuited.</p> <p>2: The connecting cable of the motor is too long.</p> <p>3: The module overheats.</p> <p>4: The internal connections become loose.</p> <p>5: The main control board is faulty.</p> <p>6: The drive board is faulty.</p> <p>7: The inverter module is faulty.</p>	<p>1: Eliminate external faults.</p> <p>2: Install a reactor or an output filter.</p> <p>3: Check the air filter and the cooling fan.</p> <p>4: Connect all cables properly.</p> <p>5: Contact the official distributor or JADEN directly.</p>
Overcurrent during acceleration	2=E.oCAC	<p>1: The output circuit is grounded or shortcircuited.</p> <p>2: Motor auto-tuning is not performed.</p> <p>3: The acceleration time is too short.</p> <p>4: Manual torque booster V/F curve is not appropriate.</p> <p>5: The voltage is too low.</p> <p>6: The startup operation is performed on the rotating motor.</p> <p>7: A sudden load is added during acceleration.</p> <p>8: The inverter model is of too small power class.</p>	<p>1: Eliminate external faults.</p> <p>2: Perform the motor auto-tuning.</p> <p>3: Increase the acceleration time.</p> <p>4: Adjust the manual torque booster V/F curve.</p> <p>5: Adjust the voltage to normal range.</p> <p>6: Select rotational speed tracking restart or start the motor after its stops.</p> <p>7: Remove the added load.</p> <p>8: Select an inverter of higher power class.</p>
Overcurrent during deceleration	3=E.oCdE	<p>1: The output circuit is grounded or shortcircuited.</p> <p>2: Motor auto-tuning is not performed.</p> <p>3: The deceleration time is too short.</p> <p>4: The voltage is too low.</p> <p>5: A sudden load is added during deceleration.</p> <p>6: The braking unit and braking resistor are not installed.</p>	<p>1: Eliminate external faults.</p> <p>2: Perform the motor auto-tuning.</p> <p>3: Increase the deceleration time.</p> <p>4: Adjust the voltage to normal range.</p> <p>5: Remove the added load.</p> <p>6: Install the braking unit and braking resistor.</p>

FaultName	Display	Possible Causes	Solutions
Overcurrent at constant speed	4=E.oCCo	1: The output circuit is grounded or short-circuited. 2: Motor auto-tuning is not performed. 3: The voltage is too low. 4: A sudden load is added during operation. 5: The inverter model is of too small power class.	1: Eliminate external faults. 2: Perform the motor auto-tuning. 3: Adjust the voltage to normal range. 4: Remove the added load. 5: Select an inverter of higher power class.
Overvoltage during acceleration	5=E.oUAC	1: The input voltage is too high. 2: An external force drives the motor during acceleration. 3: The acceleration time is too short. 4: The braking unit and braking resistor are not installed.	1: Adjust the voltage to normal range. 2: Cancel the external force or install a braking resistor. 3: Increase the acceleration time. 4: Install the braking unit and braking resistor.
Overvoltage during deceleration	6=E.oUDE	1: The input voltage is too high. 2: An external force drives the motor during deceleration. 3: The deceleration time is too short. 4: The braking unit and braking resistor are not installed.	1: Adjust the voltage to normal range. 2: Cancel the external force or install the braking resistor. 3: Increase the deceleration time. 4: Install the braking unit and braking resistor.
Overvoltage at constant speed	7=E.oUCo	1: The input voltage is too high. 2: An external force drives the motor during deceleration.	1: Adjust the voltage to normal range. 2: Cancel the external force or install the braking resistor.
Control power supply fault	8=E.CPF	The input voltage is not within the allowable range	Adjust the input voltage to the allowable range
Undervoltage	9=E.LU	1: Instantaneous power failure occurs on the input power supply. 2: The inverter's input voltage is not within the allowable range. 3: The bus voltage is abnormal. 4: The rectifier bridge and buffer resistor are faulty. 5: The drive board is faulty. 6: The main control board is faulty.	1: Reset the fault. 2: Adjust the voltage to normal range. 3: Contact the official distributor or JADEN directly.
Inverter overload	10=E.oL1	1: The load is too heavy or locked-rotor occurs on the motor. 2: The inverter model is of too small power class.	1: Reduce the load and check the motor and mechanical condition. 2: Select an inverter of higher power class.

FaultName	Display	Possible Causes	Solutions
Motor overload	11=EOlT	<p>1:F9-01 is set improperly.</p> <p>2:The load is too heavy or blocked-rotor occurs on the motor.</p> <p>3:The Inverter model is of too small power class.</p>	<p>1:Set F9-01 correctly.</p> <p>2:Reduce the load and check the motor and the mechanical condition.</p> <p>3:Select an Inverter of higher power class.</p>
Power input phase loss	12=IPHO	<p>1:The three-phase power input is abnormal.</p> <p>2:The drive board is faulty.</p> <p>3:The lightning board is faulty.</p> <p>4:The main control board is faulty.</p>	<p>1:Eliminate external faults.</p> <p>2:Contact the official distributor or JADEN directly.</p>
Power output phase loss	13=OPHO	<p>1:The cable connecting the Inverter and the motor is faulty.</p> <p>2:The Inverter's three-phase outputs are unbalanced when the motor is running.</p> <p>3:The drive board is faulty.</p> <p>4:The module is faulty.</p>	<p>1:Eliminate external faults.</p> <p>2:Check whether the motor three-phase winding is normal.</p> <p>3:Contact the official distributor or JADEN directly.</p>
Module overheat	14=EOH1	<p>1:The ambient temperature is too high.</p> <p>2:The air filter is blocked.</p> <p>3:The fan is damaged.</p> <p>4:The thermally sensitive resistor of the module is damaged.</p> <p>5:The inverter module is damaged.</p>	<p>1:Lower the ambient temperature.</p> <p>2:Clean the air filter.</p> <p>3:Replace the damaged fan.</p> <p>4:Replace the damaged thermally sensitive resistor.</p> <p>5:Replace the inverter module.</p>
External equipment fault	15=EEDF	<p>1:External fault signal is input via DI.</p> <p>2:External fault signal is input via virtual IO.</p>	<p>Reset the operation.</p>
Communication fault	16=ECOF1	<p>1:The host computer is in abnormal state.</p> <p>2:The communication cable is faulty.</p> <p>3:P0.28 is set improperly.</p> <p>4:The communication parameters in group FD are set improperly.</p>	<p>1:Check the cabling of host computer.</p> <p>2:Check the communication cabling.</p> <p>3:Set P0.28 correctly.</p> <p>4:Set the communication parameters properly.</p>
Contactor fault	17=EECF	<p>1:The drive board and power supply are faulty.</p> <p>2:The contactor is faulty.</p>	<p>1:Replace the faulty drive board or power supply board.</p> <p>2:Replace the faulty contactor.</p>

FaultName	Display	Possible Causes	Solutions
Current detection fault	18=E HALL	1:The HALL device is faulty.2:The drive board is faulty.	1:Replace the faulty HALL device. 2:Replace the faulty drive board.
Motor auto-tuning fault	19=E UNE	1:The motor parameters are not set according to the nameplate. 2:The motor auto-tuning times out.	1:Set the motor parameters according to the nameplate properly. 2:Check the cable connecting the inverter and the motor.
Encoder fault	20=E PG1	1:The encoder type is incorrect.2:The cable connection of the encoder is incorrect. 3:The encoder is damaged. 4:The PG card is faulty.	1:Set the encoder type correctly based on the actual situation. 2:Eliminate external faults. 3:Replace the damaged encoder. 4:Replace the faulty PG card.
EEPROM read-write fault	21=E EEP	The EEPROM chip is damaged.	Replace the main control board.
Inverter hardware fault	22=E HARD	1:Overvoltage exists.2:Overcurrent exists.	1:Handle based on overvoltage. 2:Handle based on overcurrent.
Short circuit to ground	23=E SHOT	The motor is short circuited to the ground	Replace the cable or motor.
Accumulative running time reached	26=E ArA	The accumulative running time reaches the setting value.	Clear the record through the parameter initialization function.
User-defined fault 1	27=E US1	1:The user-defined fault1 signal is input via DI. 2:User-defined fault1 signal is input via virtual I/O	Reset the operation.
User-defined fault 2	28=E US2	1:The user-defined fault2 signal is input via DI. 2:The user-defined fault2 signal is input via virtual I/O.	Reset the operation.
Accumulative power-on time reached	29=E APA	The accumulative power-on time reaches the setting value.	Clear the record through the parameter initialization function.
Load becoming 0	30=E ULF	The inverter running current is lower than F9-64.	Check that the load is disconnected or the setting of F9-64 and F9-65 is correct.
PD feedback loss during running	31=E PD	The PD feedback is lower than the setting of FA-26.	Check the PD feedback signal or set FA 26 to a proper value

FaultName	Display	Possible Causes	Solutions
Pulse-by-pulse current limit fault	40=E.CbC	1:The load is too heavy or blocked-rotor occurs on the motor. 2:The Inverter model is of too small power class.	1:Reduce the load and check the motor and mechanical condition. 2:Select an Inverter of higher power class.
Motor switchover fault during running	41=E.Sr	Change the selection of the motor via item in during running of the Inverter.	Perform motor switchover after the Inverter stops.
Too large speed deviation	42=E.SdL	1:The encoder parameters are set incorrectly. 2:The motor auto-tuning is not performed. 3:F9-69 and F9-70 are set incorrectly.	1:Set the encoder parameters properly. 2:Perform the motor auto-tuning. 3:Set F9-69 and F9-70 correctly based on the actual situation.
Motor over-speed	43=E.oSF	1:The encoder parameters are set incorrectly. 2:The motor auto-tuning is not performed. 3:F9-69 and F9-70 are set incorrectly.	1:Set the encoder parameters properly. 2:Perform the motor auto-tuning. 3:Set F9-69 and F9-70 correctly based on the actual situation.
Motor overheat	45=E.oHt	1:The cabling of the temperature sensor becomes loose. 2:The motor temperature is too high.	1:Check the temperature sensor cabling and eliminate the cabling fault. 2:Lower the carrier frequency or adopt other heat radiation measures.
Initial position fault	51=E.PoSf	The motor parameters are not set based on the actual situation.	Check that the motor parameters are set correctly and whether the setting of rated current is too small.

5.2 Common fault and solutions

You may come across the following faults during the use of the Inverter. Refer to the following table for simple fault analysis.

SN	Fault	Possible Causes	Solutions
1	There is no display at power-on.	1: There is no power supply to the Inverter or the power input to the Inverter is too low. 2: The power supply of the switch on the drive board of the Inverter is faulty. 3: The rectifier bridge is damaged. 4: The control board or the operation panel is faulty. 5: The cable connecting the control board and the drive board and the operation panel breaks.	1: Check the power supply. 2: Check the bus voltage. 3: Re-connect the 8-core and 28-core cables. 4: Contact the official distributor or JADEN directly for technical support.
2	"DLB1" is displayed at power-on.	1: The cable between the drive board and the control board is in poor contact. 2: Related components on the control board are damaged. 3: The motor or the motor cable is short-circuited to the ground. 4: The HALL device is faulty. 5: The power input to the Inverter is too low.	1: Re-connect the 8-core and 28-core cables. 2: Contact the official distributor or JADEN directly for technical support.
3	23=ESHOT is displayed at power-on.	1: The motor or the motor output cable is short-circuited to the ground. 2: The Inverter is damaged.	1: Measure the insulation of the motor and the output cable with a megger. 2: Contact the official distributor or JADEN directly for technical support.
4	The Inverter display is normal upon power-on. But "DLB1" is displayed after running and stops immediately.	1: The cooling fan is damaged or blocked-rotor occurs. 2: The external control terminal cable is short-circuited.	1: Replace the damaged fan. 2: Eliminate external fault.
5	14=EOH1 (module overheat) fault is reported frequently.	1: The setting of carrier frequency is too high. 2: The cooling fan is damaged, or the air filter is blocked. 3: Components inside the Inverter are damaged (thermal coupler or others).	1: Reduce the carrier frequency (P0.15). 2: Replace the fan and clean the air filter. 3: Contact the official distributor or JADEN directly for technical support.

SN	Fault	Possible Causes	Solutions
6	The motor does not rotate after the inverter runs.	1: Check the motor and the motor cables. 2: The inverter parameters are set improperly (motor parameters). 3: The cable between the drive board and the control board is in poor contact. 4: The drive board is faulty.	1: Ensure the cable between the inverter and the motor is normal. 2: Replace the motor or clear mechanical faults. 3: Check and re-set motor parameters.
7	The DI terminals are disabled.	1: The parameters are set incorrectly. 2: The external signal is incorrect. 3: The jumper bar across SP and +24V becomes loose. 4: The control board is faulty.	1: Check and reset the parameters in group P4. 2: Re-connect the external signal cables. 3: Re-confirm the jumper bar across OP and +24V. 4: Contact the official distributor or JADEN directly for technical support.
8	The motor speed is always low in FVC mode.	1: The encoder is faulty. 2: The encoder cable is connected incorrectly or in poor contact. 3: The PG card is faulty. 4: The drive board is faulty.	1: Replace the encoder and ensure the cabling is proper. 2: Replace the PG card. 3: Contact the official distributor or JADEN directly for technical support.
9	The inverter reports overcurrent and overvoltage frequently.	1: The motor parameters are set improperly. 2: The acceleration/deceleration time is improper. 3: The load fluctuates.	1: Re-set motor parameters or re-perform the motor auto-tuning. 2: Set proper acceleration/deceleration time. 3: Contact the official distributor or JADEN directly for technical support.

Warning:

Do not touch any component inside the device within 5 minutes after the (! CHARGE) light is off after power off, otherwise user is in danger of electroic shock.

Do not touch the PCB or IGBT without electrostatic protections, otherwise the internal compnents can be damaged.

6 Repair and maintenance

6.1 Routine maintenance

The influence of the ambient temperature, humidity, dust and vibration will cause the aging of the devices in the Inverter, which may cause potential faults or reduce the service life of the Inverter. Therefore, it is necessary to carry out routine and periodic maintenance.

Routine maintenance involves checking:

Item	Details	Measures
Terminal screws	Are they loose?	Tighten the screws.
Heat sink	Is it dusty?	Blow away the dust with 4 ~ 6kg/cm ² pressure dry compressed air.
PCB	Is it dusty?	Blow away the dust with 4 ~ 6kg/cm ² pressure dry compressed air.
Cooling fan	Is it noisy and with abnormal oscillations?	Relace the cooling fan
Power components	Is it dusty?	Blow away the dust with 4 ~ 6kg/cm ² pressure dry compressed air.
DC bus aluminum electrolytic capacitor	Is it discoloured, with peculiar smell or bubbles?	Relace the aluminum electrolytic capacitor

6.2 Replacement of vulnerable components

The vulnerable components of the Inverter are cooling fan and aluminum electrolytic capacitor. Their service life is related to the operating environment and maintenance status.

Generally, the service life is shown as follows:

1. Cooling fan: 3 years
2. Aluminum electrolytic capacitor: 5 years.

7 MODBUS communication protocol

7.1 Communication protocol

7.1.1 Protocol content

The serial communication protocol defines the information content and the use of serial communication transmission format, including: Host polling (or broadcast) format; host encoding method, including: action-requiring function code, data transfer & error correction; master response from the slave is the same structure, including: action confirmation, return data & error checking, etc. If an error occurs when the slave receives information, or host requested action can not be completed, it will organize a fault as a feedback information to the host.

Application mode:

Inverter joins RS232/RS485 fieldbus compatible master-slavery PC/PLC control network.

Fieldbus structure:

(1) Interface mode

RS232/RS485 hardware interface

(2) Transmission mode

Asynchronous serial, half-duplex transmission mode. At the same time there can be only one master slave transmit data while the other can only receive data. Data on the serial asynchronous communication, is in the form of packets sent frame by frame.

(3) Topological structure:

Single master multi-slave system. Slave address setting range is 1 to 247, 0 is broadcast communication address. Network slave address must be unique.

7.1.2 Protocol

DLB1 series inverter is an asynchronous serial communication Modbus master-slave communication protocol. Only one device on the network (host) can establish an agreement (called "query/command"). Other devices (slave) can only respond to the host's "query/command" by providing data, or take actions according to the host's "query/command". The host can be personal computer (PC), industrial control equipment or a programmable logic controller (PLC); slave is DLB1 inverter. Host can communicate to an independent slave machine, or can broadcast information to all slaves. For independent host "query/command", slave returns information (known as the response). For broadcast information, slave no need to send response to the host.

DLB1 series inverter Modbus data communication protocol format is as follows: using RTU mode, sending a message must start with an at least 3.5 characters interval time.

Transmittable characters are hexadecimal 0 ... 9, A... F. Network equipment keeps on detecting network bus, including interval time. When the first domain (address field) is

received, each device decodes to determine whether it is sending to themselves. After the last transmitted characters, a pause of at least 3.5-character time marks ending the message. A new message can start after this pause.

Whole message must be transmitted as a continuous stream. If there is a pause time over 1.5 a character before completion, receiver will refresh and assumes that next byte is address domain of a new message. Also, if a new message starts within a time interval of less than 3.5 character after previous message, receiver will regard the new message as continuation of previous message. This will lead to an error, because at last the CRC domain value will be wrong.

RTU frame format:

Frame START	At least 3.5 character time
Slave address ADR	Communication address:0~247
Command code CMD	03:Read slave parameter ; 06:Write slave parameter
Data content DATA(N-1)	Information:function code parameter address, function code parameter quantity, function code parameter value etc.
Data content DATA(N-2)	
.....	
Data content DATA0	
CRC CHK High place	detection value:CRC value
CRC CHK Low place	
END	At least 3.5 character time

CMD(command instruction) and DATA(description).

Command code:03H, read N words (max 12 words)

For example:Slave address is 01, start address is P0.02, continuously read 2 value.

Master command information

ADR	01H
CMD	03H
Start address high place	F0H
Start address low place	02H
Registrar number high place	00H
Registrar number low place	02H
CRC CHK low place	CRC CHK value
CRC CHK high place	

Slave response information

ADR	01H
CMD	03H
Byte number high place	00H
Byte number low place	04H
F002H high place	00H
F002H low place	00H
F003H high place	00H
F003H high place	01H
CRC CHK low place	CRC CHK value
CRC CHK high place	

Command code:06H write one word

For example:write 5000(1388H) toF00AH of slave address02H.

Master command information

ADR	02H
CMD	06H
Information address high place	F0H
Informationaddress low place	0AH
Information content high place	13H
Information content low place	88H
CRC CHK low place	CRC CHK value
CRC CHK high place	

Slave response information

ADR	02H
CMD	06H
Informationaddress high place	F0H
Informationaddress low place	0AH
Information content high place	13H
Information content low place	88H
CRC CHK low place	CRC CHK value
CRC CHK high place	

7.2 Verification mode

CRC mode: CRC (Cyclical Redundancy Check) uses RTU frame format message, includes error detection method based on CRC fields. CRC field detects the entire contents of the message. CRC field includes two bytes, and contains a 16-bit binary value. It adds to the message after calculations from the transmission equipment. The receiver recalculates the received CRC messages, and compares with CRC value in the domain. If the two CRC values do not equal, then the transmission has errors.

CRC firstly deposits 0xFFFF, then calls a consecutive 8-bit bytes in the message and processes with the value currently in the registry. Only 8-bit data from each character is valid for CRC; start and stop bits, and parity bit are invalid.

In CRC process, each 8-bit word XOR with registry separately. The result moves to the lowest valid place. Highest valid place is 0. If LSB is 1, registry value will XOR with preset values separately; if LSB is 0, then not execute. The whole process will repeat 8 times. When the last one (8th bit) completes, next 8-bit byte will start XOR with current value. CRC value is the value in the registry after all bytes are processed.

When adding CRC to a message, low byte adds first, then the high byte.

CRC calculation programs:

```
unsigned int cal_crc16 (unsigned char *data, unsigned int length)
{
    unsigned int i, crc_result=0xffff;
    while(length--)
    {
        crc_result^=*data++;
        for(i=0; i<8; i++)
        {
            if(crc_result&0x01)
                crc_result=(crc_result>>1)^0xa001;
            else
                crc_result=crc_result>>1;
        }
    }
    crc_result=((crc_result&0xff)<<8)|(crc_result>>8);
    return(crc_result);
}
```

7.3 Communication addresses

Function code address rules (EEPROM):

High place bytes: 00~0F (P0~PF, change P to 0), 40~4F (B0~BF, change B to 4), 70~7F (D0~DF).

Low place byte: 00~FF.

For example: P3.12, the address is expressed as F30C.

Note:

PF group: not readable or editable;

Group d: read-only and cannot be changed.

In addition, frequent EEPROM storage will reduce the life of the EEPROM. Some functions can be realized by changing the value of RAM. User needs to change high place byte A to 4.

Address	Function
1000	Communication setting value(-10000~10000)(decimal)
1001	Running frequency
1002	DC bus voltage
1003	Output voltage
1004	Output current
1005	Output power
1006	Output torque
1007	Running speed
1008	DI input state
1009	DO output state
100A	A11 voltage
100B	A12 voltage
100C	A13 voltage
100D	Counter input
100E	Length input
100F	Load speed
1010	PID setting
1011	PID feedback
1012	PLC sequence
1013	Input pulse frequency, unit0.01kHz
1014	Feedback speed, unit0.1Hz
1015	Remaining running time
1016	A11 voltage before correction
1017	A12 voltage before correction
1018	A13 voltage before correction
1019	Linear speed

101A	Accumulative power-on time
101B	Accumulative running time
101C	Input pulse frequency, unit1Hz
101D	Communication setting value
101E	Encoder feedback speed
101F	Main frequency X
1020	Auxiliary frequency Y

Note:

Communication setting value is relevant percentage value, 10000 corresponding to 100.00%, -10000 corresponding-100.00%. For frequency data, this percentage is relevant to maximum frequency(P0.10); torque data is percentage to P3.10(torque upper limit).

Command input:(write only)

Command address	Command function
2000	0001:FWD operation
	0002:REV operation
	0003:FWD JOG
	0004:REVJOG
	0005:Coast to stop
	0006:Decelerate to stop
	0007:Fault reset

Read inverter status:(read only)

Statusaddress	Statusfunction
3000	0001:FWD operation
	0002:REV operation
	0003:stop

Parameter lock verification:(Return value 8888H means parameter lock passed)

Passord address	Input password
1F00	*****

Digital output control:(write only)

Command address	Command content
2001	BIT0:DO1 output control BIT1:DO2 output control

	BIT2:RELAY1 output control BIT3:RELAY2 output control BIT4:FMR output control BIT5:VDO1 BIT6:VDO2 BIT7:VDO3 BIT8:VDO4 BIT9:VDO5
--	--

Analog outputAO1 control:(write only)

Command address	Command content
2002	0~7FFF for 0%~100%

Analog outputAO2 control:(write only)

Command address	Command content
2003	0~7FFF for 0%~100%

Pulse output control:(write only)

Command address	Command content
2004	0~7FFF for 0%~100%

Inverter fault description:

Inverter fault address	Inverter fault information
8000	0000:No fault 0001:reserved 0002:Over-current during acceleration 0003:Over-current during deceleration 0004:Over-current at constant speed 0005:Over-voltage during acceleration 0006:Over-voltage during deceleration 0007:Over-voltage at constant speed 0008:Control power supply fault 0009:Under-voltage 000A:Inverter over-load 000B:Motor overload 000C:Power input phase loss 000D:Power output phase loss 000E:Module over-heat 000F:External equipment fault 0010:Communication fault 0011:Contactor fault 0012:Current detection fault

	0013:Motor auto-tuning fault 0014:Encoder/PG card fault 0015:EEPROM read-write fault 0016:Inverter hardware fault 0017:Motor short circuit to ground 0018:reserved 0019:reserved 001A:Accumulative running timereached 001B:User defined fault 1 001C:User defined fault 2 001D:Accumulative power-on timereached 001E:Load becomes 0 001F:PID feedback lost during running 0028:Pulse-by-pulsecurrent limit fault 0029:Motor switchover fault during running 002A:Speed deviation too large 002B:Motor over-speed 002D:Motor over-heat 005A:Encoder line number setting fault 005B:Encoder not connected 005C: Initial position fault 005E:Speed feedback fault
--	---

Communication fault information:

Communication fault address	Faultdescription
8001	0000:No fault 0001:Wrong password 0002:Command code fault 0003:CRC detection fault 0004:Invalid address 0005:Invalid parameter 0006:Parameter editing invalid 0007:System locked 0008:Writing EEPROMin operation

Appendix I:Parameterlist

Parameter	Description	Factory setting	Setting value1	Setting value 2
d0	Monitoring function group:d0.00-d0.41			
d0.00	Running frequency (Hz)	0.01Hz		
d0.01	Set frequency (Hz)	0.01Hz		
d0.02	Bus voltage	0.1V		
d0.03	Output voltage	1V		
d0.04	Output current	0.01A		
d0.05	Output power	0.1kW		
d0.06	Output torque	0.1%		
d0.07	DI input status	0.01Hz		
d0.08	DO output status	1		
d0.09	AI1 voltage (V)	0.01V		
d0.10	AI2 voltage (V)	0.01V		
d0.11	AI3 voltage (V)	0.01V		
d0.12	Count value	1		
d0.13	Length value	1		
d0.14	Load speed	1		
d0.15	PID setting	1		
d0.16	PID feedback	1		
d0.17	PLC stage	100%		
d0.18	Input pulse frequency (Hz)	0.01kHz		
d0.19	Feedback speed	0.00Hz		
d0.20	Remaining running time	1		
d0.21	AI1 voltage before correction			
d0.22	AI2 voltage before correction			
d0.23	AI3 voltage before correction			
d0.24	Linear speed	1m/Min		
d0.25	Accumulative power-on time	1Min		
d0.26	Accumulative running time	0.1Min		
d0.27	Input pulse frequency	1Hz		
d0.28	Communication setting value	0.01%		
d0.29	Encoder feedback speed	0.01Hz		
d0.30	Main frequency X	0.01Hz		

d0.31	Auxiliary frequency Y	0.01Hz			
d0.32	Inverter status	1			
d0.33	Target torque(%)	0.1%			
d0.34	Motor temperature	1			
d0.35	Synchronous motor rotor position	0.0°			
d0.36	Resolver position	1			
d0.37	Z signal counter	-			
d0.38	ABZ position	0.0			
d0.39	Target voltage upon V/F separation	1V			
d0.40	Output voltage upon V/F separation	1V			
d0.41	Reserved				
P0	Basic functions group: P0.00-P0.28				
P0.00	Load type	-			
P0.01	Speed control mode	2			
P0.02	Command source channel	0			
P0.03	Main frequency source X selection	0			
P0.04	Auxiliary frequency source Y selection	0			
P0.05	Auxiliary frequency Y reference.	0			
P0.06	Range of auxiliary frequency Y for X and Y operation	100%			
P0.07	Frequency source combination mode	00			
P0.08	Keyboard setting frequency	50.00Hz			
P0.09	Operation direction selection	0			
P0.10	Maximum output frequency	50.00Hz			
P0.11	Frequency source upper limit	0			
P0.12	Frequency upper limit	50.00Hz			
P0.13	Frequency upper limit offset	0.00Hz			
P0.14	Frequency lower limit	0.00Hz			
P0.15	Wave carrier frequency setting	-			
P0.16	Carrier frequency adjustment with temperature	0			
P0.17	Acceleration time1	-			
P0.18	Deceleration time1	-			
P0.19	Acceleration/deceleration time unit	1			
P0.21	Frequency offset of auxiliary frequency source for X and Y operation	0.00Hz			
P0.22	Frequency reference resolution	2			
P0.23	Retentive of digital setting frequency upon power failure	0			

P0.25	Acceleration/Deceleration time base frequency	0			
P0.26	Base frequency for UP/DOWN modification during running	0			
P0.27	Binding command source to frequency source	000			
P0.28	Communication card type	0			
P1	First motor parameters: P1.00-P1.37				
P1.00	Motor type selection	0			
P1.01	Motor rated power	-			
P1.02	Motor rated voltage	-			
P1.03	Motor rated current	-			
P1.04	Motor rated frequency	-			
P1.05	Motor rated speed	-			
P1.06	Asynchronous motor stator resistance	-			
P1.07	Asynchronous motor rotor resistance	-			
P1.08	Asynchronous motor leakage inductive reactance	-			
P1.09	Asynchronous motor mutual inductive reactance	-			
P1.10	Asynchronous motor no load current	-			
P1.16	Synchronous motor stator resistance	-			
P1.17	Synchronous motor shaft D inductance	0.00Hz			
P1.18	Synchronous motor shaft Q inductance	0.0%			
P1.19	Inductance resistance unit	0.0%			
P1.20	Back EMF coefficient	0.1V			
P1.21	Phase loss detection time	0			
P1.27	Encoder pulse per revolution	2500			
P1.28	Encoder type	0			
P1.30	A/B phase sequence of ABZ incremental encoder	0			
P1.31	Encoder installation angle	0.00			
P1.32	U, V, W phase sequence of UVW encoder	0			
P1.33	UVW encoder angle offset	0.00			
P1.34	Resolver pole pairs	1			
P1.35	UVW pole pairs	4			
P1.36	Encoder wire-break fault detection time	0.0s			
P1.37	Auto-tuning selection	0			
P2	V/F control parameters: P2.00-P2.15				
P2.00	V/F curve setting	0			
P2.01	Torque boost	-			
P2.02	Torque boost cut-off frequency	50.00Hz			

P2.03	Multi-point V/F frequency 1 (F1)	0.00Hz			
P2.04	Multi-point V/F voltage 1 (V1)	0.0%			
P2.05	Multi-point V/F frequency 2 (F2)	0.00Hz			
P2.06	Multi-point V/F voltage 2 (V2)	0.0%			
P2.07	Multi-point V/F frequency 3 (F3)	0.00Hz			
P2.08	Multi-point V/F voltage 3 (V3)	0.0%			
P2.09	V/F slip compensation gain	0.0%			
P2.10	V/F over-excitation gain	64			
P2.11	V/F oscillation suppression gain	-			
P2.13	Voltage source for V/F separation	0			
P2.14	Voltage digital setting for V/F separation	0V			
P2.15	Voltage rise time of V/F separation	0.0s			
P3	Vector control parameters: P3.00-P3.15				
P3.00	Speed loop proportional gain 1	30			
P3.01	Speed loop integral time 1	0.50s			
P3.02	Switchover frequency 1	5.00Hz			
P3.03	Speed loop proportional gain 2	20			
P3.04	Speed loop integral time 2	1.00s			
P3.05	Switchover frequency 2	0.00Hz			
P3.06	Vector control slip gain	150%			
P3.07	Time constant of speed loop filter	0.000s			
P3.08	Vector control over-excitation gain	64			
P3.09	Torque upper limit source in speed control mode	0.0%			
P3.10	Digital setting of torque upper limit in speed control mode	150.0%			
P3.13	Excitation adjustment proportional gain	2000			
P3.14	Excitation adjustment integral gain	1300			
P3.15	Torque adjustment proportional gain	2000			
P3.16	Torque adjustment integral gain	1300			
P3.17	Speed loop integral	0			
P3.18	Field weakening mode of synchronous motor	1			
P3.19	Field weakening depth of synchronous motor	100%			
P3.20	Maximum field weakening current	50%			
P3.21	Field weakening automatic adjustment gain	100%			

P3.22	Field weakening integral multiple	5			
P4	Input terminals:P4.00-P4.39				
P4.00	DI1 function selection	1			
P4.01	DI2 function selection	4			
P4.02	DI3 function selection	9			
P4.03	DI4 function selection	12			
P4.04	DI5 function selection	13			
P4.05	DI6 function selection	2			
P4.06	DI7 function selection	12			
P4.07	DI8 function selection	13			
P4.08	DI9 function selection	14			
P4.09	DI10 function selection	15			
P4.10	DI filter time	0.010s			
P4.11	Terminal command mode	0			
P4.12	Terminal UP/DOWN rate	1.00Hz/s			
P4.13	AI curve 1 minimum input	0.00V			
P4.14	Corresponding setting of AI curve 1 minimum input	0.0%			
P4.15	AI curve 1 maximum input	10.00V			
P4.16	Corresponding setting of AI curve 1 maximum input	100.0%			
P4.17	AI1 filter time	0.10s			
P4.18	AI curve 2 minimum input	0.00V			
P4.19	Corresponding setting of AI curve 2 minimum input	0.0%			
P4.20	AI curve 2 maximum input	10.00V			
P4.21	Corresponding setting of AI curve 2 maximum input	100.0%			
P4.22	AI2 filter time	0.10s			
P4.23	AI curve 3 minimum input	10V			
P4.24	Corresponding setting of AI curve 3 minimum input	0%			
P4.25	AI curve 3 maximum input	00V			
P4.26	Corresponding setting of AI curve 3 maximum input	00.0%			
P4.27	AI3 filter time	10s			
P4.28	Pulse minimum input	0.00kHz			
P4.29	Corresponding setting of pulse minimum input	0%			
P4.30	Pulse maximum input	0.00			

P4.31	Corresponding setting of pulse maximum input	00.0%			
P4.32	Pulse filter time	.10s			
P4.33	AI curve selection	321			
P4.34	Setting for AI less than minimum input	000			
P4.35	DI1 delay time	0.0s			
P4.36	DI2 delay time	0.0s			
P4.37	DI3 delay time	0.0s			
P4.38	DI valid mode selection 1	00000			
P4.39	DI valid mode selection 2	00000			
P5	Output terminals:P5.00-P5.22				
P5.00	FM output mode	0			
P5.01	FMR function (open-collector output terminal)	0			
P5.02	Relay function 1 (T/A-T/B-T/C)	2			
P5.03	Extension card relay function 2 (P/A-P/B-P/C)	2			
P5.04	DO1 function selection (open-collector output terminal)	1			
P5.05	DO2 function selection (open-collector output terminal)	1			
P5.06	FMP output selection	0			
P5.07	AO1 output selection	0			
P5.08	AO2 output selection	1			
P5.09	FMP output maximum frequency	50.00kHz			
P5.10	AO1 zero offset coefficient	0.0%			
P5.11	AO1 gain	1.00			
P5.12	AO2 zero offset coefficient	0.00%			
P5.13	AO2 gain	1.00			
P5.17	FMR output delay time	0.0s			
P5.18	Relay 1 output delay time	0.0s			
P5.19	Relay 2 output delay time	0.0s			
P5.20	DO1 output delay time	0.0s			
P5.21	DO2 output delay time	0.0s			
P5.22	DO valid mode selection	00000			
P6	Start/stop control:P6.00-P6.15				
P6.00	Start mode	0			
P6.01	Speed track mode	0			
P6.02	Rotational speed tracking speed				

P6.03	Startup frequency	0.00Hz			
P6.04	Startup frequency holding time	0.0s			
P6.05	Startup DC braking current/Pre-excited current	0%			
P6.06	Startup DC braking time/Pre-excited time	0.0s			
P6.07	Acceleration/deceleration mode	0			
P6.08	Time proportion of S-curve start segment	30.0%			
P6.09	Time proportion of S-curve end segment	30.0%			
P6.10	Stop mode	0			
P6.11	Initial frequency of stop DC braking	0.00Hz			
P6.12	Waiting time of stop DC braking	0.0s			
P6.13	Stop DC braking current	0%			
P6.14	Stop DC braking time	0.0s			
P6.15	Brake use ratio	100%			
P7	Operation panel and display:P7.00-P7.14				
P7.01	DIR/JOG function	0			
P7.02	STOP/RESET	1			
P7.03	LED display running parameters 1	1F			
P7.04	LED display running parameters 2	0			
P7.05	LEDdisplay stopparameters	33			
P7.06	Load speed display coefficient	1.0000			
P7.07	Heatsink temperature of inverter module	12			
P7.08	Rectification module temperature	0			
P7.09	Accumulativerunning time	0h			
P7.10	Product number	-			
P7.11	Software version	-			
P7.12	Number of decimal places for load speed display	1			
P7.13	Accumulative power-on time	-			
P7.14	Accumulative power consumption	-			
P8	Auxiliary functions: P8.00-P8.53				
P8.00	JOG running frequency	2.00Hz			
P8.01	JOG acceleration time	20.0s			
P8.02	JOG deceleration time	20.0s			
P8.03	Acceleration time 2	10.0s			
P8.04	Deceleration time 2	10.0s			
P8.05	Acceleration time 3	10.0s			

P8.06	Deceleration time 3	10.0s			
P8.07	Acceleration time 4	10.0s			
P8.08	Deceleration time 4	10.0s			
P8.09	Jump frequency 1	0.00Hz			
P8.10	Jump frequency 2	0.00Hz			
P8.11	Frequency jump amplitude	0.00Hz			
P8.12	Forward/Reverse rotation dead-zone time	0.0s			
P8.13	Reverse control	0			
P8.14	Running mode when set frequency lower than frequency lower limit	0			
P8.15	Droop control	0.00Hz			
P8.16	Accumulative power-on time threshold	0h			
P8.17	Accumulative running time threshold	0h			
P8.18	Startup protection	0			
P8.19	Frequency detection value (FDT1)	50.00Hz			
P8.20	Frequency detection hysteresis (FDT hysteresis 1)	5.0%			
P8.21	Detection range of frequency reached	0.0%			
P8.22	Jump frequency during acceleration/deceleration	0			
P8.25	Frequency switchover point between acceleration time 1 and acceleration time 2	0.00Hz			
P8.26	Frequency switchover point between deceleration time 1 and deceleration time 2	0.00Hz			
P8.27	Terminal JOG preferred	0			
P8.28	Frequency detection value (FDT2)	50.00Hz			
P8.29	Frequency detection hysteresis (FDT hysteresis 2)	5.0%			
P8.30	Any frequency reaching detection value 1	50.00Hz			
P8.31	Any frequency reaching detection amplitude 1	0.0%			
P8.32	Any frequency reaching detection value 2	50.00Hz			
P8.33	Any frequency reaching detection amplitude 2	0.0%			
P8.34	Zero current detection level	5.0%			
P8.35	Zero current detection delay time	0.10s			
P8.36	Output over-current threshold	200.0%			
P8.37	Output over-current detection delay time	0.00s			
P8.38	Any current reaching 1	100.0%			
P8.39	Any current reaching amplitude 1	0.0%			
P8.40	Any current reaching 2	100.0%			
P8.41	Any current reaching amplitude 2	0.0%			

P8.42	Timing function	0			
P8.43	Timing duration source	0			
P8.44	Timing duration	0.0Min			
P8.45	AI1 input voltage lower limit	3.10V			
P8.46	AI1 input voltage upper limit	6.80V			
P8.47	Module temperature threshold	75			
P8.48	Cooling fan control	0			
P8.49	Wakeup frequency	0.00Hz			
P8.50	Wakeup delay time	0.0s			
P8.51	Dormant frequency	0.00Hz			
P8.52	Dormant delay time	0.0s			
P8.53	Current running time reached	0.0Min			
P9	Fault and protection: P9.00-P9.70				
P9.00	Motor overload protection selection	1			
P9.01	Motor overload protection gain	1.00			
P9.02	Motor overload warning coefficient	80%			
P9.03	Over-voltage stall gain	0			
P9.04	Over-voltage stall protective voltage	130%			
P9.05	Over-current stall gain	20			
P9.06	Over-current stall protective current	150%			
P9.07	Short-circuit to ground upon power- on	1			
P9.09	Fault auto reset times	0			
P9.10	DO action during fault auto reset	0			
P9.11	Time interval of fault auto reset	1.0s			
P9.12	Input phase loss protection	11			
P9.13	Output phase loss protection selection	1			
P9.14	1st fault type	-			
P9.15	2nd fault type	-			
P9.16	3rd (latest) fault type	-			
P9.17	Frequency upon 3rd fault	-			
P9.18	Current upon 3rd fault	-			
P9.19	Bus voltage upon 3rd fault	-			
P9.20	DI status upon 3rd fault	-			
P9.21	Output terminal status upon 3rd fault	-			
P9.22	3rd faultinverter status	-			

P9.23	Power-on time upon 3rd fault	-			
P9.24	Running time upon 3rd fault	-			
P9.27	Frequency upon 2nd fault	-			
P9.28	Current upon 2nd fault	-			
P9.29	Bus voltage upon 2nd fault	-			
P9.30	DI status upon 2nd fault	-			
P9.31	Output terminal status upon 2nd fault	-			
P9.32	2nd fault inverter status	-			
P9.33	Power-on time upon 2nd fault	-			
P9.34	Running time upon 2nd fault	-			
P9.37	Frequency upon 1st fault	-			
P9.38	Current upon 1st fault	-			
P9.39	Bus voltage upon 1st fault	-			
P9.40	DI status upon 1st fault	-			
P9.41	Output terminal status upon 1st fault	-			
P9.42	1st fault inverter status	-			
P9.43	Power-on time upon 1st fault	-			
P9.44	Running time upon 1st fault	-			
P9.47	Fault protection action selection 1	00000			
P9.48	Fault protection action selection 2	00000			
P9.49	Fault protection action selection 3	00000			
P9.50	Fault protection action selection 4	00000			
P9.54	Frequency selection for continuing to run upon fault	0			
P9.55	Backup frequency upon abnormality	100.0%			
P9.56	Type of motor temperature sensor	0			
P9.57	Motor overheat protection threshold	110			
P9.58	Motor overheat warning threshold	90			
P9.59	Action selection at instantaneous power failure				
P9.60	Action pause judging voltage at instantaneous power failure	90.0%			
P9.61	Voltage rally judging time at instantaneous power failure	0.50s			
P9.62	Action judging voltage at instantaneous power failure	80.0%			
P9.63	Protection upon load becoming 0	0			

P9.64	Detection level of load becoming 0	10.0%			
P9.65	Detection time of load becoming 0	1.0s			
P9.67	Over-speed detection value	20.0%			
P9.68	Over-speed detection time	1.0s			
P9.69	Detection value of too large speed deviation	20.0%			
P9.70	Detection time of too large speed deviation	5.0s			
PA	PID functions:PA.00-PA.28				
PA.00	PID setting source	0			
PA.01	PID digital setting	50.0%			
PA.02	PID feedback source	0			
PA.03	PID action direction	0			
PA.04	PID feedback range	1000			
PA.05	Proportional gain K_{p1}	20.0			
PA.06	Integral time T_{i1}	2.00s			
PA.07	Differential time T_{d1}	0.000s			
PA.08	Cut-off frequency of PID reverse rotation	2.00Hz			
PA.09	PID deviation limit	0.0%			
PA.10	PID differential limit	0.10%			
PA.11	PID setting change time	0.00s			
PA.12	PID feedback filter time	0.00s			
PA.13	PID output filter time	0.00s			
PA.14	Reserved	-			
PA.15	Proportional gain K_{p2}	20.0			
PA.16	Integral time T_{i2}	2.00s			
PA.17	Differential time T_{d2}	0.000s			
PA.18	PID parameter switchover condition	0			
PA.19	PID parameter switchover deviation 1	20.0%			
PA.20	PID parameter switchover deviation 2	80.0%			
PA.21	PID initial value	0.0%			
PA.22	PID initial value holding time	0.00s			
PA.23	Maximum deviation between two PID outputs in forward direction	1.00%			

PA.24	Maximum deviation between two PID outputs in reverse direction	1.00%			
PA.25	PID integral property	00			
PA.26	Detection value of PID feedback loss	0.0%			
PA.27	Detection time of PID feedback loss	0s			
PA.28	PID operation at stop	0			
PB	Swing frequency, fixed length and count:PB.00-PB.09				
PB.00	Swing frequency setting mode	0			
PB.01	Swing frequency amplitude	0.0%			
PB.02	Jump frequency amplitude	0.0%			
PB.03	Swing frequency cycle	10.0s			
PB.04	Triangular wave rising time coefficient	50.0%			
PB.05	Set length	1000m			
PB.06	Actual length	0m			
PB.07	Number of pulses per meter	100.0			
PB.08	Set count value	1000			
PB.09	Designated count value	1000			
PC	Multi-reference and simple PLC: PC.00-PC.51				
PC.00	Multi-reference 0	0.0%			
PC.01	Multi-reference 1	0.0%			
PC.02	Multi-reference 2	0.0%			
PC.03	Multi-reference 3	0.0%			
PC.04	Multi-reference 4	0.0%			
PC.05	Multi-reference 5	0.0%			
PC.06	Multi-reference 6	0.0%			
PC.07	Multi-reference 7	0.0%			
PC.08	Multi-reference 8	0.0%			
PC.09	Multi-reference 9	0.0%			
PC.10	Multi-reference 10	0.0%			
PC.11	Multi-reference 11	0.0%			
PC.12	Multi-reference 12	0.0%			
PC.13	Multi-reference 13	0.0%			

PC.14	Multi-reference 14	0.0%			
PC.15	Multi-reference 15	0.0%			
PC.16	Simple PLC running mode	0			
PC.17	Simple PLC retentive selection upon power failure	00			
PC.18	Running time of simple PLC reference 0	0.0s(h)			
PC.19	Acceleration/deceleration time of simple PLC reference 0	0			
PC.20	Running time of simple PLC reference 1	0.0s(h)			
PC.21	Acceleration/deceleration time of simple PLC reference 1	0			
PC.22	Running time of simple PLC reference 2	0.0s(h)			
PC.23	Acceleration/deceleration time of simple PLC reference 2	0			
PC.24	Running time of simple PLC reference 3	0.0s(h)			
PC.25	Acceleration/deceleration time of simple PLC reference 3	0			
PC.26	Running time of simple PLC reference 4	0.0s(h)			
PC.27	Acceleration/deceleration time of simple PLC reference 4	0			
PC.28	Running time of simple PLC reference 5	0.0s(h)			
PC.29	Acceleration/deceleration time of simple PLC reference 5	0			
PC.30	Running time of simple PLC reference 6	0.0s(h)			
PC.31	Acceleration/deceleration time of simple PLC reference 6	0			
PC.32	Running time of simple PLC reference 7	0.0s(h)			
PC.33	Acceleration/deceleration time of simple PLC reference 7	0			
PC.34	Running time of simple PLC reference 8	0.0s(h)			
PC.35	Acceleration/deceleration time of simple PLC reference 8	0			
PC.36	Running time of simple PLC reference 9	0.0s(h)			
PC.37	Acceleration/deceleration time of simple PLC reference 9	0			

PC.38	Running time of simple PLC reference 10	0.0s(h)			
PC.39	Acceleration/deceleration time of simple PLC reference 10	0			
PC.40	Running time of simple PLC reference 11	0.0s(h)			
PC.41	Acceleration/deceleration time of simple PLC reference 11	0			
PC.42	Running time of simple PLC reference 12	0.0s(h)			
PC.43	Acceleration/deceleration time of simple PLC reference 12	0			
PC.44	Running time of simple PLC reference 13	0.0s(h)			
PC.45	Acceleration/deceleration time of simple PLC reference 13	0			
PC.46	Running time of simple PLC reference 14	0.0s(h)			
PC.47	Acceleration/deceleration time of simple PLC reference 14	0			
PC.48	Running time of simple PLC reference 15	0.0s(h)			
PC.49	Acceleration/deceleration time of simple PLC reference 15	0			
PC.50	Time unit of simple PLC running	0			
PC.51	Reference 0 source	0			
Pd	Communication parameters: Pd.00-Pd.06				
Pd.00	Bit rate	6005			
Pd.01	Data type	0			
Pd.02	This device address	1			
Pd.03	Response delay	2			
Pd.04	Communication over-time	0.0			
Pd.05	Data transfer format	30			
Pd.06	Current resolution	0			
PE	Reserved				
PP	Function code management: PP.00-PP.04				
PP.00	User password	0			
PP.01	Parameter initialization	0			
PP.02	Inverterparameter display property	01			
PP.03	Parameter display selection	00			

PP.04	Parameter modification property	0			
B0	Torque control parameters: B0.00-B0.08				
B0.00	Speed/Torque control selection	0			
B0.01	Torque setting source in torque control	0			
B0.03	Torque digital setting in torque control	150%			
B0.05	Forward maximum frequency in torque control	0.00Hz			
B0.06	Reverse maximum frequency in torque control	0.00Hz			
B0.07	Acceleration time in torque control	0.00s			
B0.08	Deceleration time in torque control	0.00s			
B5	Control optimization parameters: B5.00-B5.09				
B5.00	DPWM switchover frequency upper limit	12.00Hz			
B5.01	PWM modulation mode	0			
B5.02	Dead zone compensation mode selection	1			
B5.03	Random PWM depth	0			
B5.04	Rapid current limit	1			
B5.05	Current detection compensation	5			
B5.06	Undervoltage threshold	100.0%			
B5.07	SVC optimization mode selection	1			
B5.08	Dead-zone time adjustment	150%			
B5.09	Overvoltage threshold	810.0V			
B9	Extended function parameters: B9.00-B9.09				
B9.00	Load type	0			
B9.01	User-defined parameter 0	0			
B9.02	User-defined parameter 1	0			
B9.03	User-defined parameter 2	0			
B9.04	User-defined parameter 3	0			
B9.05	User-defined parameter 4	0			
B9.06	User-defined parameter 5	0			
B9.07	User-defined parameter 6	0			
B9.08	User-defined parameter 7	0			
B9.09	User-defined parameter 8	0			

Appendix II:Expansion cards

Appendix II-1 Multi-function card DLB1-PC1

1Introduction

DLB1-PC1 card provides the following functions:

Item	Specification	Description
Input terminal	2 DI	DI7~DI8
Output terminal	1 relay output	TA2, TB2, TC2
	1 DO	DO2
Communication	RS-485 communication	Supports Modbus-RTU communication protocol
	CAN communication	Supports CANlink communication protocol

2Mechanical installations

- 1)Please install at power-off status;
- 2)Align correctly DLB1-PC1 to inverter control board interface;
- 3)Fasten with double-screw bolts.

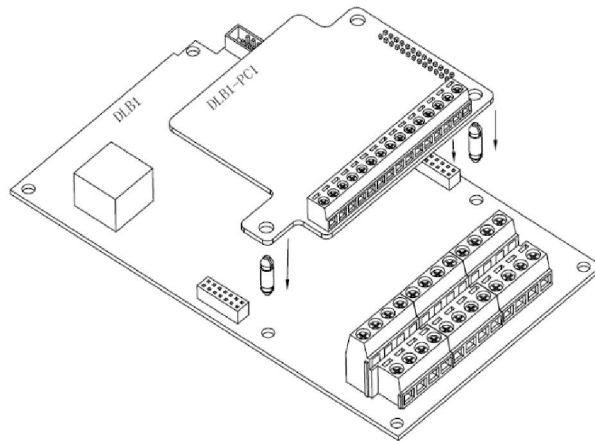

3 Terminal functions

Type	Terminal	Name	Function
Power	+24V-COM	+24V power output	Maximum output current: 200mA.
	SP1	Digital input power terminal	Default SP1 connects to +24V by jumper J1. If use external power supply, user must connect SP1 to external power supply and remove jumper J1.
DI terminal	DI7-SP1	Digital input 7	1, Optical-coupler isolation, compatible with bipolar input; 2, Input impedance: 4.7k Ω ; 3, Voltage range: 9~30V.
	DI8-SP1	Digital input 8	
DO terminal	DO2-COM	Digital output 2	Optical-coupler isolation, bipolar open collector output. Output voltage range: 0V~24V. Output current range: 0mA~50mA.
Relay output (RELAY2)	TA2-TC2	Normally open terminal	AC250V, 3A, COS ϕ = 0.4. DC30V, 1A.
	TB2-TC2	Normally close terminal	
RS-485 communication	485+/485-	Communication terminal	Modbus-RTU protocol communication input & output signal terminal. Isolated input.
CAN communication	CANH/CANL	Communication terminal	CANlink protocol communication input terminal. Isolated input.

Jumper

Number	Description
J1	SP1 connection mode selection
JP1	RS485 terminus compatible resistor selection

Appendix II-2 Encoder card (PG card)

1 Introduction

DLB1 supports different kinds of encoder cards(PG card) as optional parts for closed-loop vector controls. PG card models are as below:

Name	Description	Others
DLB1-PG1	ABZUVW incremental encoder: Differential input PG card, not with frequency demultiplication output; OC input PG card, not with frequency demultiplication output 5V, 12V, 24V voltage optional. When ordering, provide voltage&pulse input mode information	Terminal cables
DLB1-PG2	Resolver PG card	Terminal cables

2 Mechanical installations

- 1) Please install at power-off status;
- 2) Use 14-Pin base to connect with PG card.

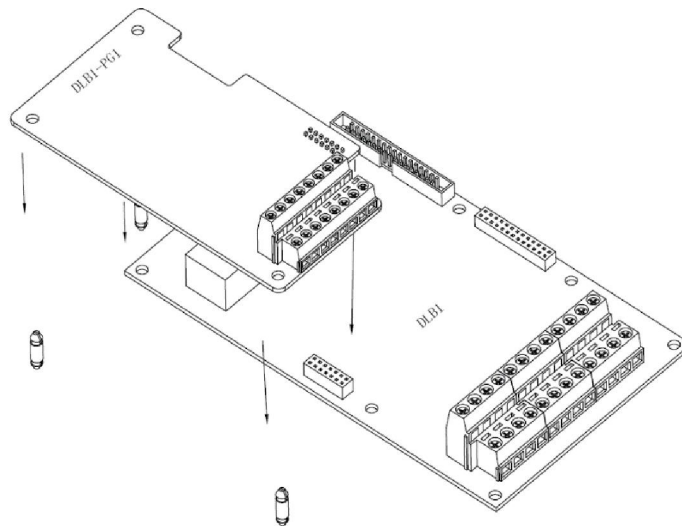

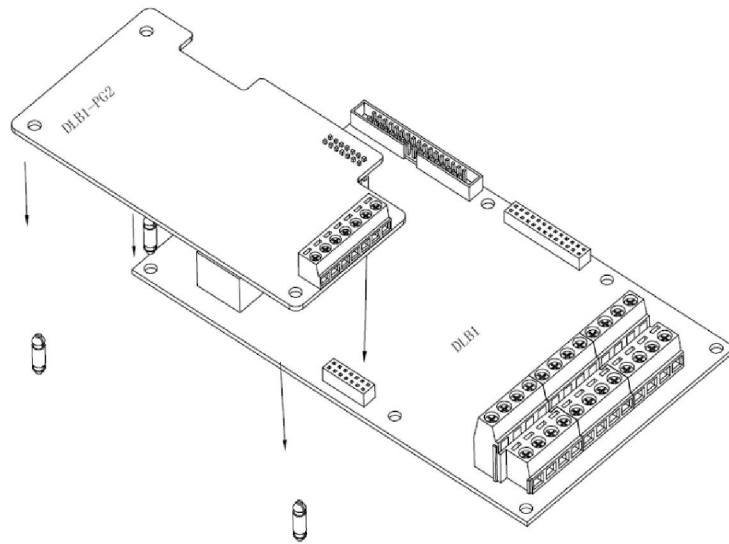

3 Terminal functions

ABZUVW differential PGcard		
DLB1-PG1 specifications		
User terminal	DB15 base	
Pulling & plugging	Yes	
Cable requirement	>22AWG	
Maximum speed	500kHz	
Input differential signal range	7V	
DLB1-PG1 terminals		
Serial number	Mark	Description
1	A+	Encoder output A signal positive
2	A-	Encoder output A signal negative
3	B+	Encoder output B signal positive
4	B-	Encoder output B signal negative
5	Z+	Encoder output Z signal positive
6	Z-	Encoder output Z signal negative
7	U+	Encoder output U signal positive
8	U-	Encoder output U signal negative
9	V+	Encoder output V signal positive
10	V-	Encoder output V signal negative
11	W+	Encoder output W signal positive
12	W-	Encoder output W signal negative
13	+5V	5V/100mA
14	COM	Power grounding
15	Shielding	Shielding

DLB1-PG1 jumper:

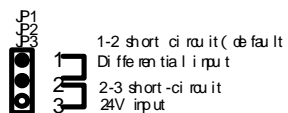

- I JP1, JP2, JP3 jumper must be the same.
- I 12 short-circuit is for ABZ differential input.
- I 23 short-circuit is for signal grade 24VA+, B+, Z+.

Resolver PG card (DLB1-PG2)		
DLB1-PG2 Specifications		
User terminal	DB7 terminal	
Pulling & plugging	No	
Cable requirement	>22AWG	
Resolution	12 bit	
Excitation frequency	10kHz	
VRMS	7V	
VP-P	3.15±27%	
DLB1-PG2 terminals		
Serial number	Mark	Description
1	PEXC1	Resolver excitation negative
2	PEXC	Resolver excitation positive
3	PSINLO	Resolver feedbackSIN negative
4	PSIN	Resolver feedbackSIN positive
5	PCOSLO	Resolver feedbackCOS negative
6	PCOS	Resolver feedbackCOS positive
7	PE	Connect to chassis

Appendix III Brake accessories

The motor and load's regenerative energy is almost completely consumed on the braking resistor when braking.

In theory, the power of the braking resistor is consistent with the braking power. But in consideration that the de-rating is 70%, you can calculate the power of the braking resistor according to the formula $0.7 \times Pr = Pb \times D$.

- Pr refers to the power of resistor.
- D refers to the braking frequency (percentage of the regenerative process to the whole working process)

◀ **Note:** brake unit and brake resistor must be used together.

For DLB1 series inverters, models under 15KW are with internal brake units and user shall select external brake units for models over 18.5KW.

You can select different resistance and power based on actual needs. However, the resistance must not be lower than the recommended value. The power may be higher than the recommended value.

The braking resistor model is dependent on the generation power of the motor in the actual system and is also related to the system inertia, deceleration time and potential energy load. For systems with high inertia, and/or rapid deceleration times, or frequent braking sequences, the braking resistor with higher power and lower resistance value should be selected.

Recommended value of brake units and brake resistors

380V class:

Inverter capacity	Brake unit		Recommended brake resistor (100% brake torque)	
	Specification	Quantity	Equivalent resistance value/power	Quantity
0.75G	Internal	1	1800 /60W	1
0.75P/1.1G		1	900 /100W	1
1.1G/1.5P		1	600 /150W	1
1.5G/2.2P		1	400 /260W	1
2.2G/3.7P		1	250 /260W	1
3.7G		1	150 /390W	1
5.5G/5.5P/7.5P		1	100 /520W	1
7.5G		1	75 /780W	1

11G/11P		1	50 /1040W	1
15G/18.5P		1	40 /1560W	1
18.5G/22P		1	32 /4800W	1
22G/30P	External	1	20 /6000W	1
30G/37P		1	20 /6000W	1
37G/45P		2	32 /4800W	1*2 (in parallel)
45G/55P		2	32 /4800W	1*2 (in parallel)
55G/75P	External	1	20 /6000W	1*2 (in parallel)
75G/93P		1	18 /9600W	1*2 (in parallel)
93G		1	18 /9600W	1*2 (in parallel)

660V class:

Inverter capacity	Brake unit		Recommended brake resistor (100% brake torque)	
	Specification	Quantity	Equivalent resistance value/power	Quantity
18.5G/22P		1	80 /2200W	1
22G/30P		1	80 /2200W	1
30G/37P		1	60 /3000W	1
37G/45P		1	48 /3700W	1
45G/55P		1	40 /4500W	1
55G/75P		1	32 /5500W	1
75G/93		1	24 /7500W	1
93		1	20 /9000W	1

Appendix IV: Selection of Peripheral Electrical Devices

Selecting Peripheral Electrical Devices for DLB1 inverters

Input voltage: 380V

Inverter Model	MCCB	Contact or	Cable of Input Side Main Circuit (mm ²)	Cable of Output Side Main Circuit (mm ²)	Cable of Control Circuit (mm ²)
DLB1-0D40T4G/DLB1-0D75T4P	10	10	2.0	2.0	1.0
DLB1-0D75T4G/DLB1-01D1T4P	10	10	2.5	2.5	1.0
DLB1-01D1T4G/ DLB1-01D5T4P	16	10	2.5	2.5	1.0
DLB1-01D5T4G/ DLB1-02D2T4P	20	16	4.0	2.5	1.0
DLB1-02D2T4G/ DLB1-03D7T4P	25	20	4.0	4.0	1.0
DLB1-03D7T4G/ DLB1-05D5T4P	32	25	4.0	4.0	1.0
DLB1-05D5T4G/ DLB1-07D5T4P	40	25	4.0	4.0	1.0
DLB1-07D5T4G/ DLB1-0011T4P	40	32	4.0	4.0	1.0
DLB1-0011T4G/ DLB1-0015T4P	63	40	6.0	4.0	1.0
DLB1-0015T4G/ DLB1-18D5T4P	63	40	6.0	6.0	1.0
DLB1-18D5T4G/ DLB1-0022T4P	100	63	6	6.0	1.5
DLB1-0022T4G/ DLB1-0030T4P	100	63	10	10	1.5
DLB1-0030T4G/ DLB1-0037T4P	125	100	16	16	1.5
DLB1-0037T4G/ DLB1-0045T4P	160	100	25	16	1.5
DLB1-0045T4G/ DLB1-0055T4P	200	125	35	25	1.5
DLB1-0055T4G/ DLB1-0075T4P	200	125	50	35	1.5
DLB1-0075T4G/ DLB1-0093T4P	250	160	95	50	1.5
DLB1-0093T4G/DLB1-0110T4P	250	160	120	70	1.5
DLB1-0110T4G/DLB1-0132T4P	350	350	185	120	1.5
DLB1-0132T4P/DLB1-0160T4G	400	400	2×120	150	1.5
DLB1-0160T4G/DLB1-0185T4P	500	400	2×120	185	1.5
DLB1-0185T4G/DLB1-0200T4P	600	600	2×150	2×95	1.5
DLB1-0200T4G/DLB1-220T4P	600	600	2×150	2×95	1.5
DLB1-0220T4G/DLB1-250T4P	600	600	2×185	2×120	1.5
DLB1-0250T4G/DLB1-280T4P	800	600	2×185	2×120	1.5

DLB1-0280T4G/DLB1-315T4P	1000	1000	3x185	2x150	1.5
DLB1-0315T4G/DLB1-355T4P	1000	1000	3x185	3x150	1.5
DLB1-0355T4G/DLB1-400T4P	1200	1200	4x185	3x185	1.5
DLB1-0400T4G	1380	1380	4x185	3x185	1.5

Input voltage: 660V

Inverter Model	MCCB	Contacto	Cable of Input Side Main Circuit (mm ²)	Cable of Output Side Main Circuit (mm ²)	Cable of Control Circuit (mm ²)
DLB1-18D5T7G/ DLB1-0022T7P	63	40	6.0	6.0	1.0
DLB1-0022T7G/ DLB1-0030T7P	63	40	6.0	6.0	1.0
DLB1-0030T7G/ DLB1-0037T7P	63	63	10	10	1.0
DLB1-0037T7G/ DLB1-0045T7P	100	63	10	10	1.0
DLB1-0045T7G/ DLB1-0055T7P	100	63	16	16	1.5
DLB1-0055T7G/ DLB1-0075T7P	125	100	25	16	1.5
DLB1-0075T7G/ DLB1-0093T7P	160	125	35	25	1.5
DLB1-0093T7G/DLB1-0110T7P	200	125	50	35	1.5
DLB1-0110T7G/DLB1-0132T7P	200	125	95	70	1.5
DLB1-0132T7G/DLB1-0160T7P	250	160	120	95	1.5
DLB1-0160T7G/DLB1-0185T7P	350	350	185	120	1.5
DLB1-0185T7G/DLB1-0200T7P	350	350	185	150	1.5
DLB1-0200T7G/DLB1-0220T7P	400	350	2x120	185	1.5
DLB1-0220T7G/DLB1-0250T7P	400	400	2x120	185	1.5
DLB1-0250T7G/DLB1-0280T7P	400	400	2x150	2x120	1.5
DLB1-0280T7G/DLB1-0315T7P	500	400	2x150	2x150	1.5
DLB1-0315T7G/DLB1-0355T7P	600	600	2x185	2x150	1.5
DLB1-0355T7G/DLB1-0400T7P	600	600	2x185	2x185	1.5
DLB1-0400T7G	800	600	3x185	3x150	1.5

Selection of external AC & DC reactor
Input voltage:380V

Inverter model	Input AC reactor		output AC reactor		DC reactor	
	Current (A)	Inductance (mH)	Current (A)	Inductance (mH)	Current (A)	Inductance (mH)
DLB1-0D40T4G/DLB1-0D75T4P	3	11	3	7	-	-
DLB1-0D75T4G/DLB1-01D11T4P	5	6	5	4		
DLB1-01D11T4G/ DLB1-01D5T4P	5	5	5	3	-	-
DLB1-01D5T4G/ DLB1-02D2T4P	10	1.4	10	0.69	-	-
DLB1-02D2T4G/ DLB1-03D7T4P	10	1.4	10	0.69	-	-
DLB1-03D7T4G/ DLB1-05D5T4P	10	1.4	10	0.69	-	-
DLB1-05D5T4G/ DLB1-07D5T4P	15	0.93	15	0.5	-	-
DLB1-07D5T4G/ DLB1-0011T4P	20	0.7	20	0.35	-	-
DLB1-0011T4G/ DLB1-0015T4P	30	0.49	30	0.24	-	-
DLB1-0015T4G/ DLB1-18D5T4P	40	0.34	40	0.17	-	-
DLB1-18D5T4G/ DLB1-0022T4P	50	0.3	50	0.14	40	1.15
DLB1-0022T4G/ DLB1-0030T4P	60	0.24	60	0.12	50	0.92
DLB1-0030T4G/ DLB1-0037T4P	80	0.17	80	0.088	65	0.71
DLB1-0037T4G/ DLB1-0045T4P	90	0.15	90	0.077	80	0.58
DLB1-0045T4G/ DLB1-0055T4P	120	0.12	120	0.06	95	0.486
DLB1-0055T4G/ DLB1-0075T4P	150	0.09	150	0.047	120	0.385
DLB1-0075T4G/ DLB1-0093T4P	200	0.068	200	0.035	160	0.288
DLB1-0093T4G/DLB1-0110T4P	220	0.063	220	0.032	180	0.256
DLB1-0110T4G/DLB1-0132T4P	250	0.055	250	0.028	250	0.26
DLB1-0132T4G/DLB1-0160T4P	300	0.047	300	0.023	250	0.26
DLB1-0160T4G/DLB1-0185T4P	330	0.041	330	0.021	360	0.17
DLB1-0185T4G/DLB1-0200T4P	400	0.034	400	0.017	500	0.12
DLB1-0200T4G/DLB1-0220T4P	450	0.03	450	0.015	650	0.072
DLB1-0220T4G/DLB1-0250T4P	500	0.027	500	0.014	650	0.072
DLB1-0250T4G/DLB1-0280T4P	580	0.024	580	0.012	800	0.06
DLB1-0280T4G/DLB1-0315T4P	660	0.021	660	0.011	800	0.06
DLB1-0315T4G/DLB1-0355T4P	660	0.021	660	0.011	900	0.05
DLB1-0355T4G/DLB1-0400T4P	800	0.017	800	8.65uH	900	0.05
DLB1-0400T4G	1000	0.014	1000	6.80uH	1200	0.042

Input voltage:660V

Inverter model	input AC reactor		output AC reactor		DC reactor	
	Current (A)	Inductance (mH)	Current (A)	Inductance (mH)	Current (A)	Inductance (mH)
DLB1-18D5T7G/ DLB1-0022T7P	20.6	1.83	20.2	0.94	25.3	5.5
DLB1-0022T7G/ DLB1-0030T7P	24.5	1.54	24	0.79	30	4.6
DLB1-0030T7G/ DLB1-0037T7P	33.5	1.13	32.8	0.58	41	3.3
DLB1-0037T7G/ DLB1-0045T7P	41	0.92	40	0.47	50.5	2.8
DLB1-0045T7G/ DLB1-0055T7P	49	0.77	48	0.39	60	2.3
DLB1-0055T7G/ DLB1-0075T7P	60	0.63	58.8	0.32	73.5	1.9
DLB1-0075T7G/ DLB1-0093T7P	81	0.47	79.6	0.24	99.6	1.4
DLB1-0093T7G/DLB1-0110T7P	96	0.39	94	0.2	117.8	1.2
DLB1-0110T7G/DLB1-0132T7P	116.8	0.32	114	0.17	143	0.96
DLB1-0132T7G/DLB1-0160T7P	139.7	0.27	136.9	0.14	171	0.81
DLB1-0160T7G/DLB1-0185T7P	169	0.22	165.7	0.11	207	0.66
DLB1-0185T7G/DLB1-0200T7P	195.5	0.19	191.6	0.1	239.5	0.57
DLB1-0200T7G/DLB1-0220T7P	211	0.18	207	0.09	259	0.54
DLB1-0220T7G/DLB1-0250T7P	237.9	0.16	233	0.08	291	0.48
DLB1-0250T7G/DLB1-0280T7P	269	0.14	264	0.07	330	0.42
DLB1-0280T7G/DLB1-0315T7P	301.8	0.13	295.7	0.06	369.6	0.39
DLB1-0315T7G/DLB1-0355T7P	343	0.11	332.7	0.06	420	0.33
DLB1-0355T7G/DLB1-0400T7P	386	0.1	374.6	0.05	473	0.3
DLB1-4000T7G	442	0.086	428.8	0.044	541.5	0.26

Using Peripheral Electrical Devices for DLB1

See table below:

Name	Installation position	Functions
Air switch	Before input circuit	Cut-off current when the device is over-current
Contactor	Input side of inverter	On-off power supply for inverters.
Input AC reactor	Input side of inverter	1) Increase power factor of input side; 2) Reduce input side higher harmonics; 3) Eliminate input current imbalance caused by power phase imbalance.
Input EMC filter	Input side of inverter	1) Reduce inverter EMI transmission and emission; 2) Improve inverter counter interference capability.
DC reactor	DC bus of inverter	1) Increase power factor of input side; 2) Increase inverter efficiency&thermal stability; 3) Reduce negative effects from input side higher harmonics and reduce inverter EMI transmission and emission.
Output AC reactor	Output side of inverter and input side of motor, close to inverter	1) Protect motors from higher harmonics; 2) Reduce effects of leakage current to motors.

Appendix V: Guide for complying with EMC

EMC basics

Electromagnetic compatibility (EMC) describes the ability of electronic and electrical devices or systems to work properly in the electromagnetic environment and not to generate electromagnetic interference that influences other local devices or systems.

In other words, EMC includes two aspects: The electromagnetic interference generated by a device or system must be restricted within a certain limit; the device or system must have sufficient immunity to the electromagnetic interference in the environment.

EMC of inverters

Inverters, same as other electronic devices, are EMI sources and receivers. Characteristics of inverter EMC includes:

1. Input current are not sine-wave and with a lot of higher harmonic waves.
2. Output voltage is high-frequency PWM waves which can cause a lot of EMI.
3. The process of reducing inverter EMI is also the process of enhancing inverter counter-EMI capabilities.

EMC Installations

The Inverter generates very strong interference. Although EMC measures are taken, the interference may still exist due to improper cabling or grounding during use. When the Inverter interferes with other devices, adopt the following solutions.

Interference Type	Solution
Leakage protection switch tripping	<ul style="list-style-type: none"> • Connect the motor housing to the PE of the Inverter. • Connect the PE of the Inverter to the PE of the mains power supply. • Add a safety capacitor to the power input cable. • Add magnetic rings to the input drive cable.
Inverter interference	<ul style="list-style-type: none"> • Connect the motor housing to the PE of the Inverter. • Connect the PE of the Inverter to the PE of the mains voltage. • Add a safety capacitor to the power input cable and wind the cable with magnetic rings. • Add a safety capacitor to the interfered signal port or wind the signal cable with magnetic rings. • Connect the equipment to the common ground.
Communication interference	<ul style="list-style-type: none"> • Connect the motor housing to the PE of the Inverter. • Connect the PE of the Inverter to the PE of the mains voltage. • Add a safety capacitor to the power input cable and wind the cable with magnetic rings. • Add a matching resistor between the communication cable source and the load side. • Add a common grounding cable besides the communication cable. • Use a shielded cable as the communication cable and connect the cable shield to the common grounding point.
I/O interference	<ul style="list-style-type: none"> • Enlarge the capacitance at the low-speed DI. A maximum of 0.11 uF capacitance is suggested. • Enlarge the capacitance at the AI. A maximum of 0.22 uF is suggested.

Appendix VI: Safety instructions

Read this part carefully so that you have a thorough understanding. Installation, commissioning or maintenance may be performed in conjunction with this chapter. JADEN will assume no liability or responsibility for any injury or loss caused by improper operation.

Ø Before installation

- Do not install the equipment if you find water seepage, component missing or damage upon unpacking.
- Do not install the equipment if the packing list does not conform to the product you received.
- Handle the equipment with care during transportation to prevent damage to the equipment.
- Do not use the equipment if any component is damaged or missing. Failure to comply will result in personal injury.
- Do not touch the components with your hands. Failure to comply will result in static electricity damage.

Ø During installation

- Install the equipment on incombustible objects such as metal, and keep it away from combustible materials. Failure to comply may result in a fire.
- Do not loosen the fixed screws of the components, especially the screws with red mark.
- Do not drop wire end or screw into the inverter. Failure to comply will result in damage to the inverter.
- Install the Inverter in places free of vibration and direct sunlight.
- When two Inverters are laid in the same cabinet, arrange the installation positions properly to ensure the cooling effect.

Ø At wiring

- Wiring must be performed only by qualified personnel under instructions described in this manual. Failure to comply may result in unexpected accidents.
- A circuit breaker must be used to isolate the power supply and the inverter. Failure to comply may result in a fire.

- Ensure that the power supply is cut off before wiring. Failure to comply may result in electric shock.
- Tie the inverter to ground properly by standard. Failure to comply may result in electric shock.
- Never connect the power cables to the output terminals (U, V, W) of the inverter. Pay attention to the marks of the wiring terminals and ensure correct wiring. Failure to comply will result in damage to the inverter.
- Never connect the braking resistor between the DC bus terminals(+) and (-). Failure to comply may result in a fire.
- Use wire sizes recommended in the manual. Failure to comply may result in accidents.
- Use a shielded cable for the encoder, and ensure that the shielding layer is reliably grounded.

Ø **Before power-on**

- Check that the following requirements are met:
 - The voltage class of the power supply is consistent with the rated voltage class of the inverter.
 - The input terminals (R, S, T) and output terminals (U, V, W) are properly connected.
 - No short-circuit exists in the peripheral circuit.
 - The wiring is secured.

Failure to comply will result in damage to the inverter

- Do not perform the voltage resistance test on any part of the inverter because such test has been done in the factory. Failure to comply will result in accidents.
- Cover the inverter properly before power-on to prevent electric shock.
- All peripheral devices must be connected properly under the instructions described in this manual. Failure to comply will result in accidents

Ø **After power-on**

- Do not open the inverter's cover after power-on. Failure to comply may result in electric shock.
- Do not touch any I/O terminal of the inverter. Failure to comply may result in electric shock.
- Do not touch the rotating part of the motor during the motor auto-tuning or running. Failure to comply will result in accidents.

- Do not change the default settings of the Inverter. Failure to comply will result in damage to the Inverter.

Ø **During operation**

- Do not touch the fan or the discharging resistor to check the temperature. Failure to comply will result in personal burnt.
- Signal detection must be performed only by qualified personnel during operation. Failure to comply will result in personal injury or damage to the Inverter.
- Avoid objects falling into the Inverter when it is running. Failure to comply will result in damage to the Inverter.
- Do not start/stop the Inverter by turning the contactor ON/OFF. Failure to comply will result in damage to the Inverter.

thomas@cn-JADEN; Skype: thomas.lt65

Ø **During maintenance**

- Repair or maintenance of the Inverter may be performed only by qualified personnel. Failure to comply will result in personal injury or damage to the Inverter.
- Do not repair or maintain the Inverter at power-on. Failure to comply will result in electric shock.
- Repair or maintain the Inverter only ten minutes after the Inverter is powered off. This allows for the residual voltage in the capacitor to discharge to a safe value. Failure to comply will result in personal injury.
- Ensure that the Inverter is disconnected from all power supplies before starting repair or maintenance on the Inverter.
- Set and check the parameters again after the Inverter is replaced.
- All the pluggable components must be plugged or removed only after power-off.
- The rotating motor generally feeds back power to the Inverter. As a result, the Inverter is still charged even if the motor stops, and the power supply is cut off. Thus ensure that the Inverter is disconnected from the motor before starting repair or maintenance on the Inverter.